

Max. Door Weight: Max. 120kg.
 Door Thickness: Max. 44mm.

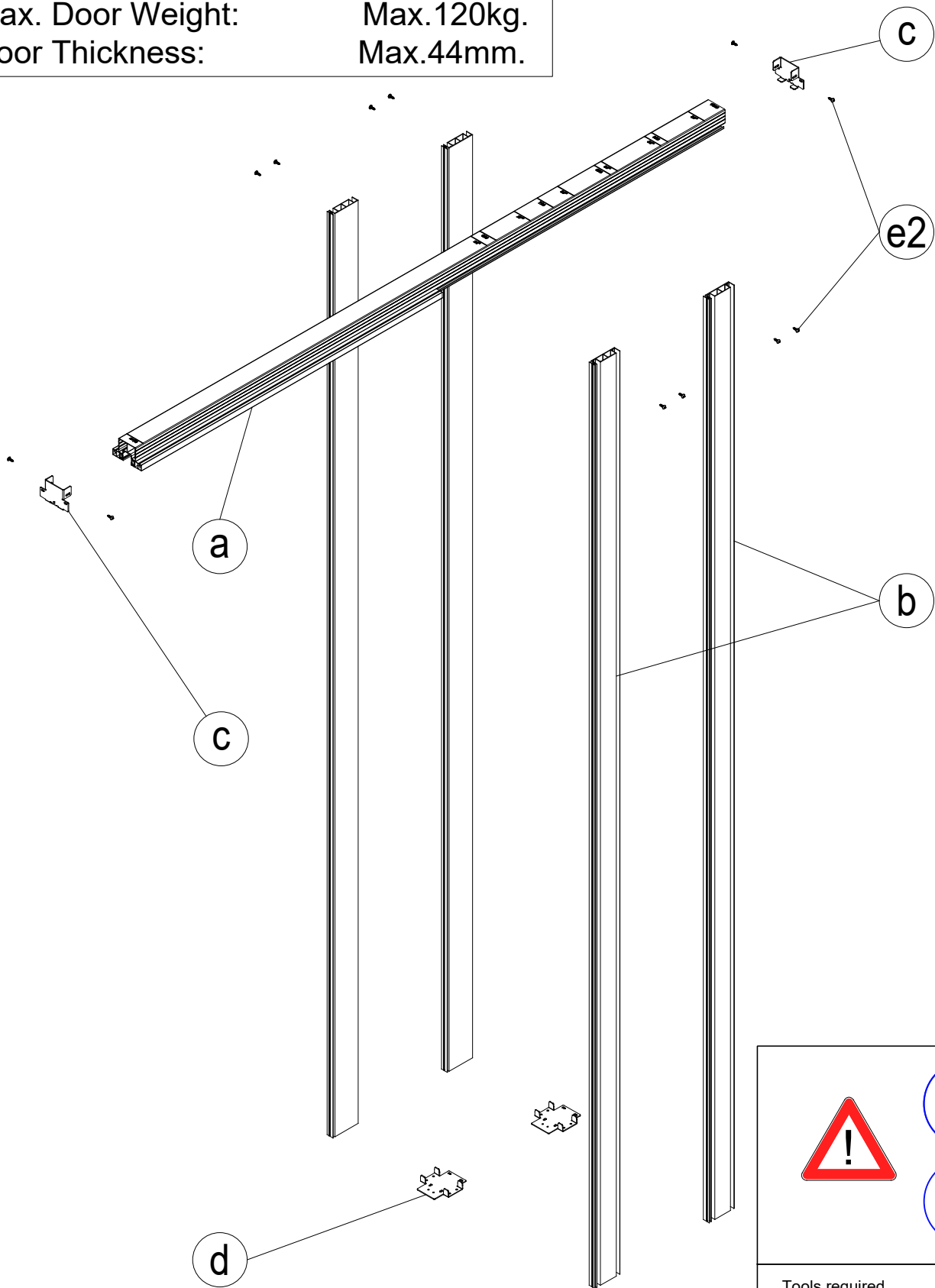

PART LIST:

- a** 1 x
- b** 4 x
- b1** 1 x
- c** 2 x
- d** 2 x
- e** 1 x
- e2** 2 x
- f** 1 x
- g** 1 x
- h** 1 x

Tools required

- Gloves
- Electric screwdriver
- Scissors
- Hammer
- Spirit level
- PH.2 Bits
- Tape measure
- Plumb line
- Saw
- 2x No13 spanner

REQUIRED PRE-INSTALLATION INSTRUCTIONS

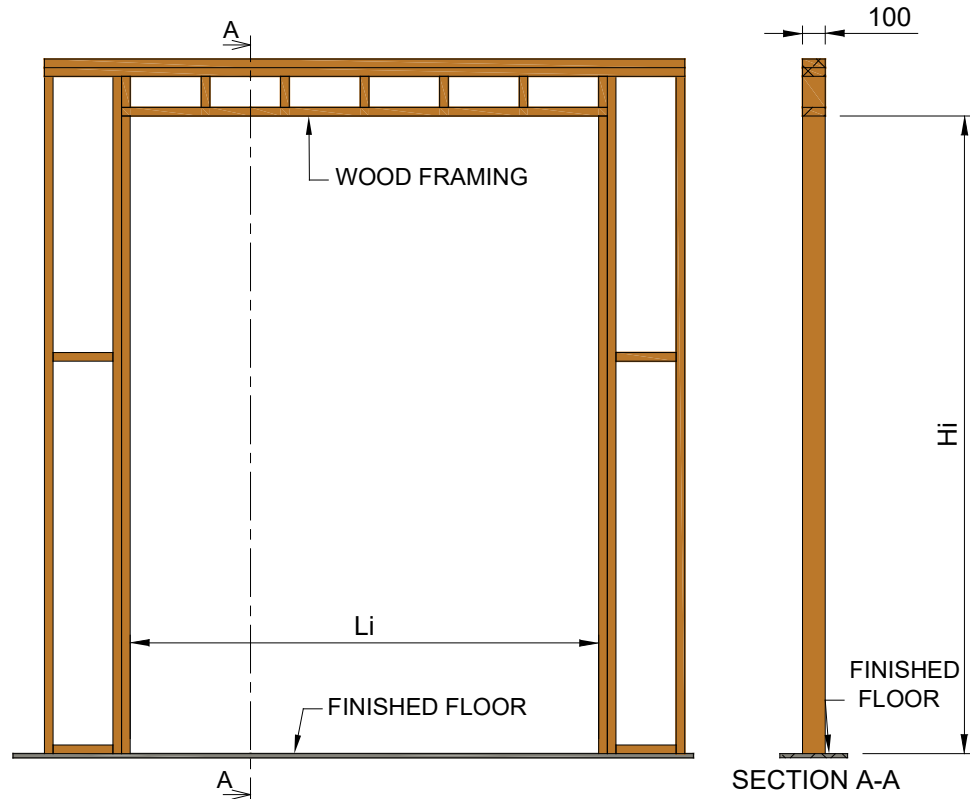

SINGLE DOOR OPENINGS

CHART METRIC/IMPERIAL: ROUGH OPENING SIZE

METRIC	DOOR WIDTH	STRUCTURAL OPENING WIDTH (Li)	IMPERIAL	DOOR WIDTH	STRUCTURAL OPENING WIDTH (Li)	HEIGHT DOORS (Hd)	STRUCTURAL OPENING HEIGHT (Hi) FROM FINISHED FLOOR:
	626	1266		610 (24")	1234	MIN 1981 MAX 2710	Hd + 200mm
	726	1466		686 (27")	1386		
	-	-		762 (30")	1538		
	826	1666		838 (33")	1690		
	926	1866		914 (36")	1842		
	1026	2066		990 (39")	1994		

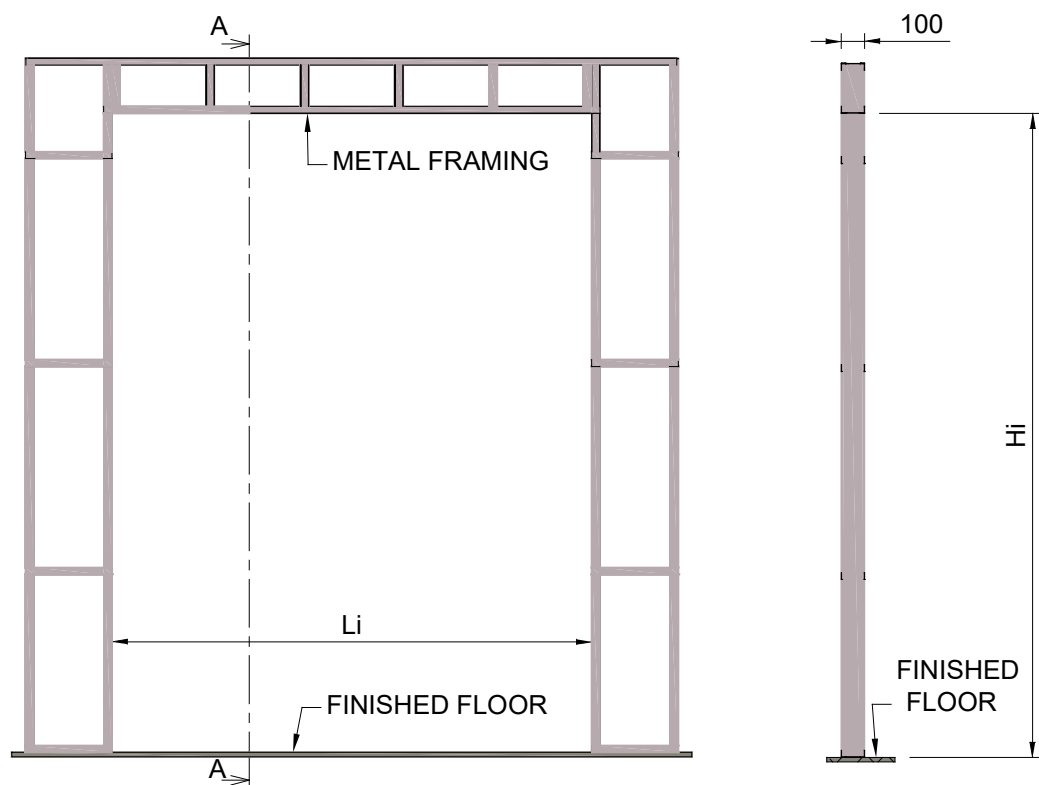

FRAMING DETAILS MAY DIFFER BASED ON REGION. REFER TO YOUR REGION'S BUILDING CODES FOR FRAMING DETAILS.

SIZE CHANGES

Cut track "1" to the desired size on the rear side.
Cut PVC profile bars "2" on the front side.

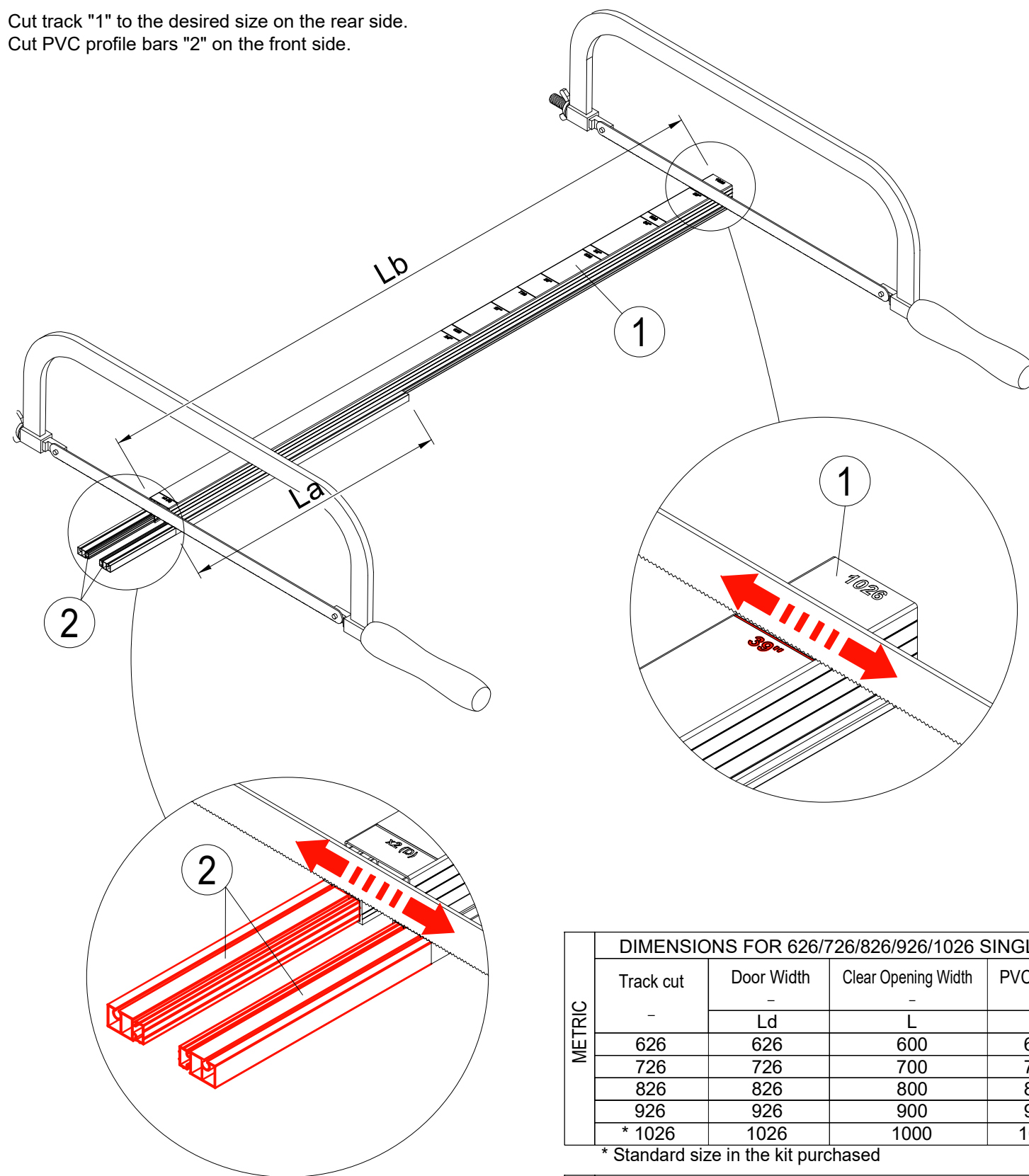

METRIC	DIMENSIONS FOR 626/726/826/926/1026 SINGLE DOOR				
	Track cut	Door Width	Clear Opening Width	PVC length	Rail length
	-	-	-	-	-
		Ld	L	La	Lb
	626	626	600	653	1262
	726	726	700	753	1462
	826	826	800	853	1662
	926	926	900	953	1862
	* 1026	1026	1000	1053	2062

* Standard size in the kit purchased

IMPERIAL	DIMENSIONS FOR 24"/27"/30"/33"/36"/39" SINGLE DOOR				
	Track cut	Door Width	Clear Opening Width	PVC length	Rail length
	-	-	-	-	-
		Ld	L	La	Lb
	24"	24"(610)	23"(584)	637	1230
	27"	27"(686)	25"(660)	713	1382
	30"	30"(762)	28"(736)	789	1534
	33"	33"(838)	31"(812)	865	1686
	36"	36"(914)	34"(888)	941	1838
	39"	39"(990)	37"(964)	1017	1990

PLAN VIEW INSTRUCTIONS SINGLE DOOR

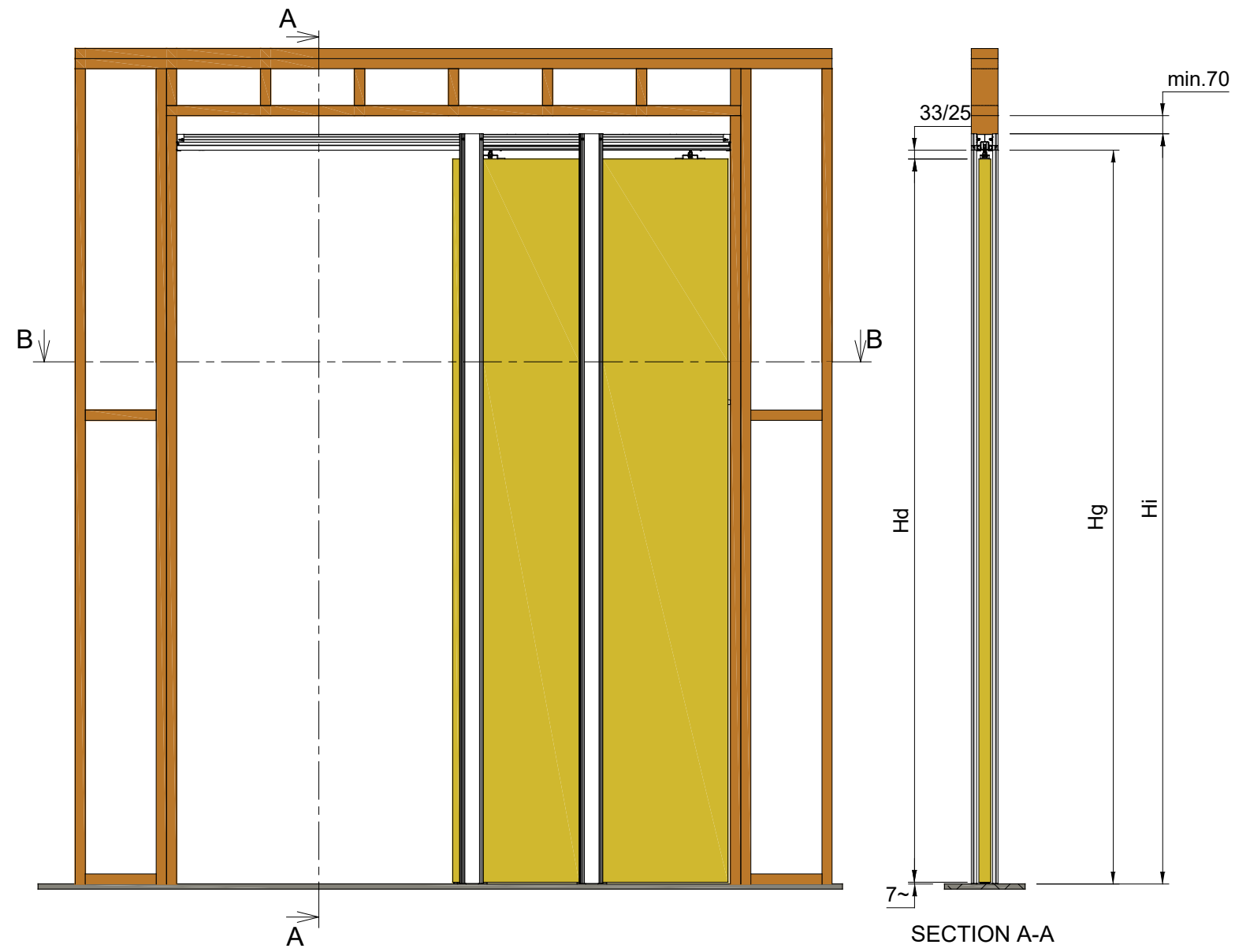

DIMENSIONS FOR 626/726/826/926/1026 SINGLE DOOR						
Door Width	Dimension "A"	Dimension "B"	Opening Width without jamb	Cassette dimension	Structural opening width	Structural opening height
Ld	A	B	Lg	Lc	Li	Hi
626	620	320	655	611	1266	Hd+200
726	720	370	755	711	1466	
826	820	420	855	811	1666	
926	920	520	955	911	1866	
1026	1020	620	1055	1011	2066	

DIMENSIONS FOR 24"/27"/30"/33"/36"/39" SINGLE DOOR						
Door Width	Dimension "A"	Dimension "B"	Opening Width without jamb	Cassette dimension	Structural opening width	Structural opening height
Ld	A	B	Lg	Lc	Li	Hi
24"(610)	604	316	639	595	1234	Hd+200
27"(686)	680	356	715	671	1386	
30"(762)	756	396	791	747	1538	
33"(838)	832	432	867	823	1690	
36"(914)	908	508	943	899	1842	
39"(990)	984	584	1019	975	1994	

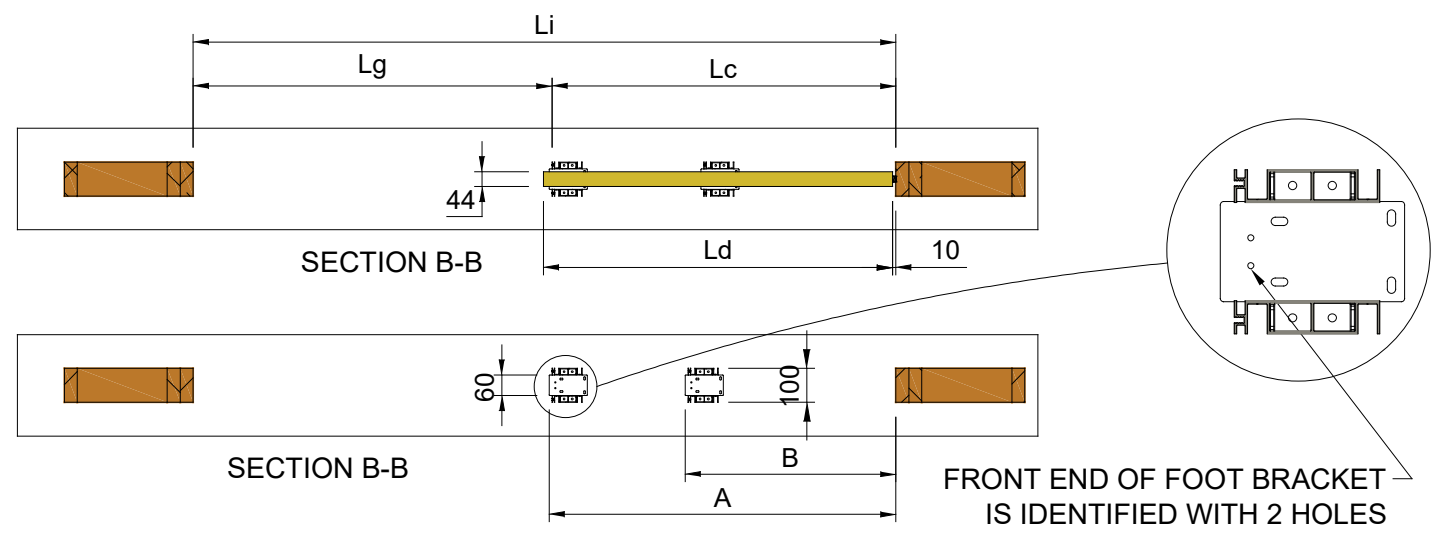
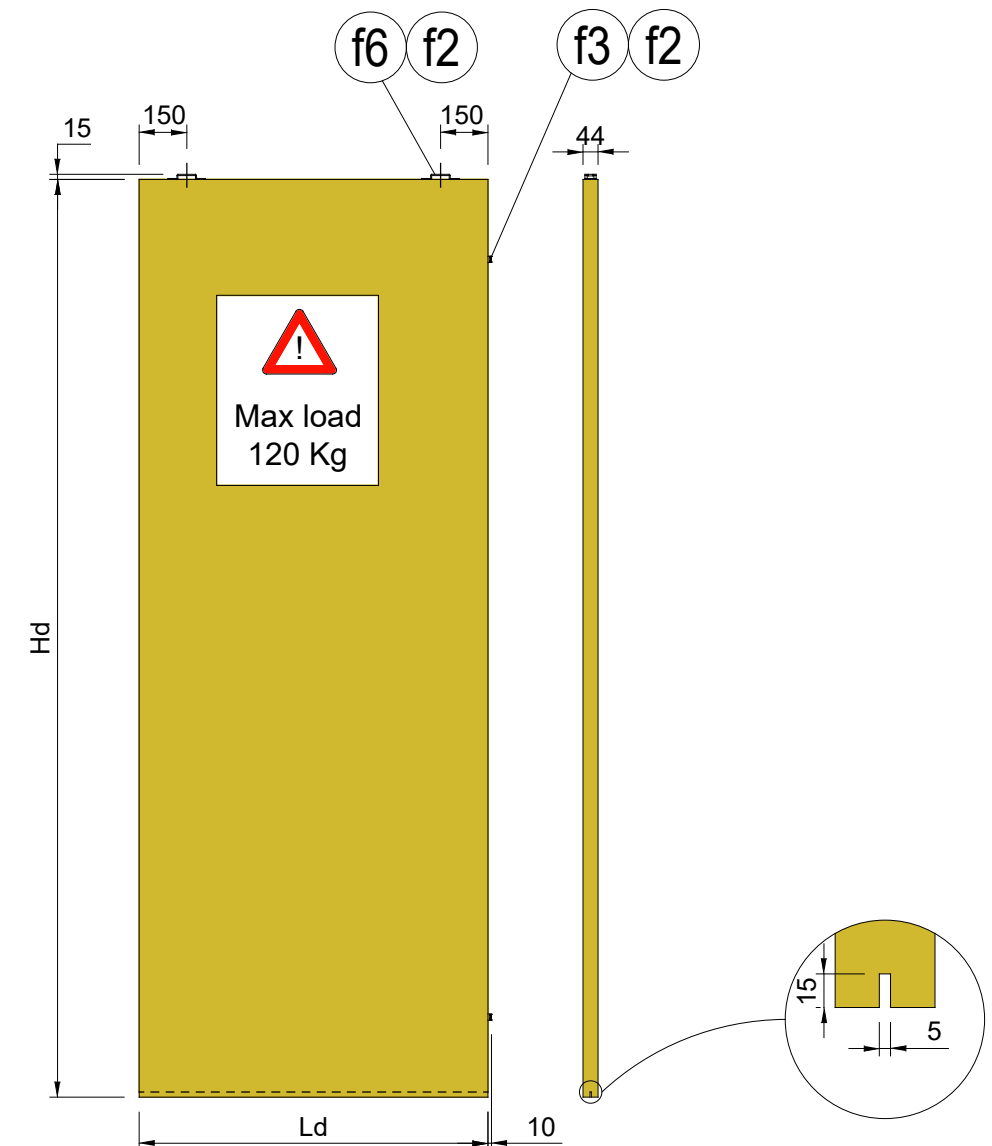

PLAN VIEW INSTRUCTIONS

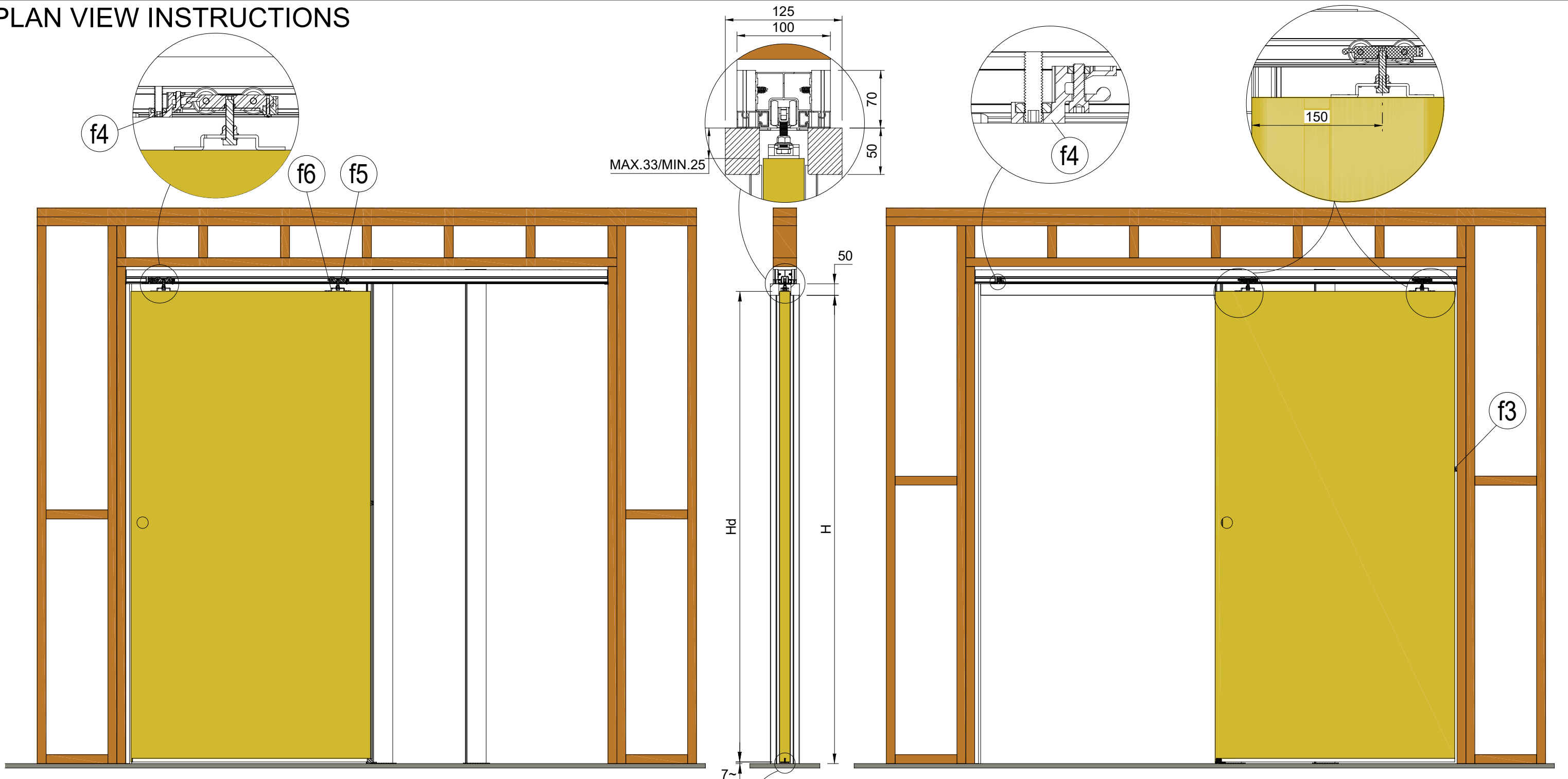

(DOOR IN CLOSED POSITION)

(DOOR IN OPENED POSITION)

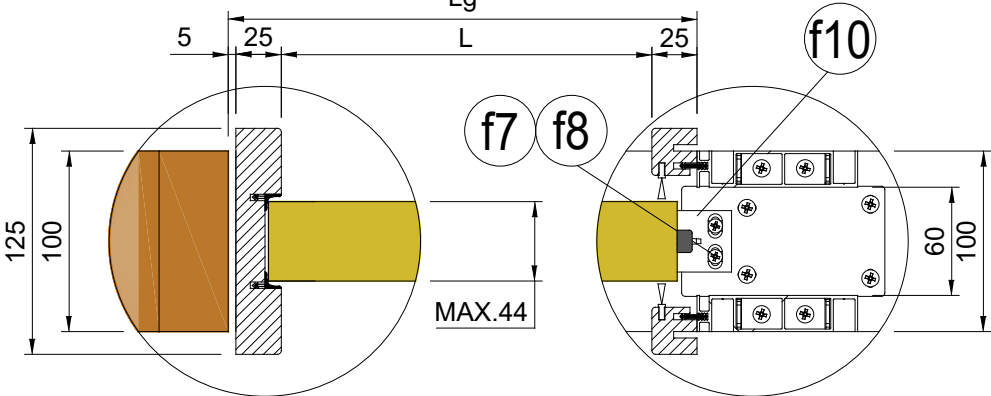
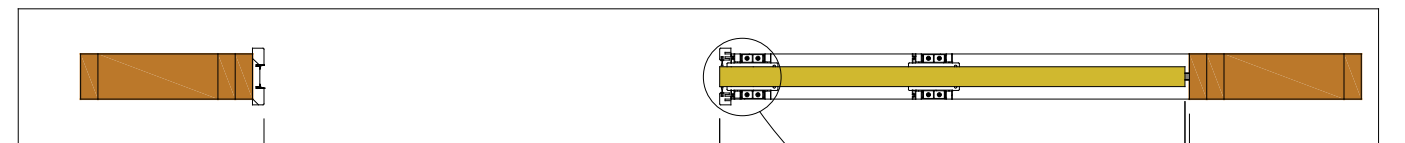
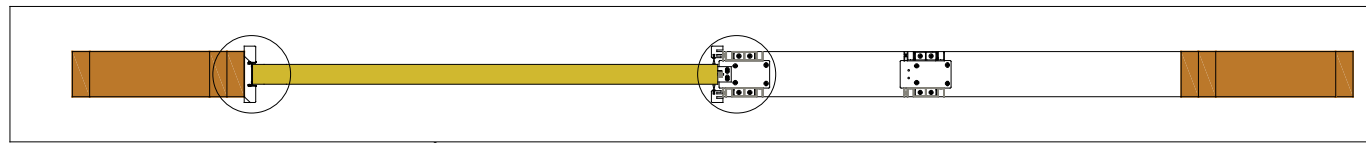

IMPERIAL	Door Width	Clear Opening Width	Opening Width	Clear Opening Height
	Ld	L	Lg	H
	24"(610)	23"(584)	639	Hp -10
	27"(686)	25"(660)	715	
	30"(762)	28"(736)	791	
	33"(838)	31"(812)	867	
	36"(914)	34"(888)	943	
	39"(990)	37"(964)	1019	

METRIC	Door Width	Clear Opening Width	Opening Width	Clear Opening Height
	Ld	L	Lg	H
	626	600	655	Hp -10
	726	700	755	
	826	800	855	
	926	900	955	
	1026	1000	1055	

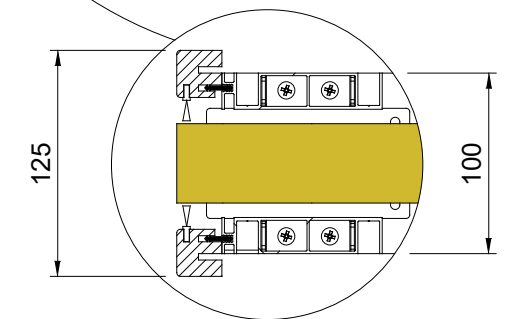

STEP 1:

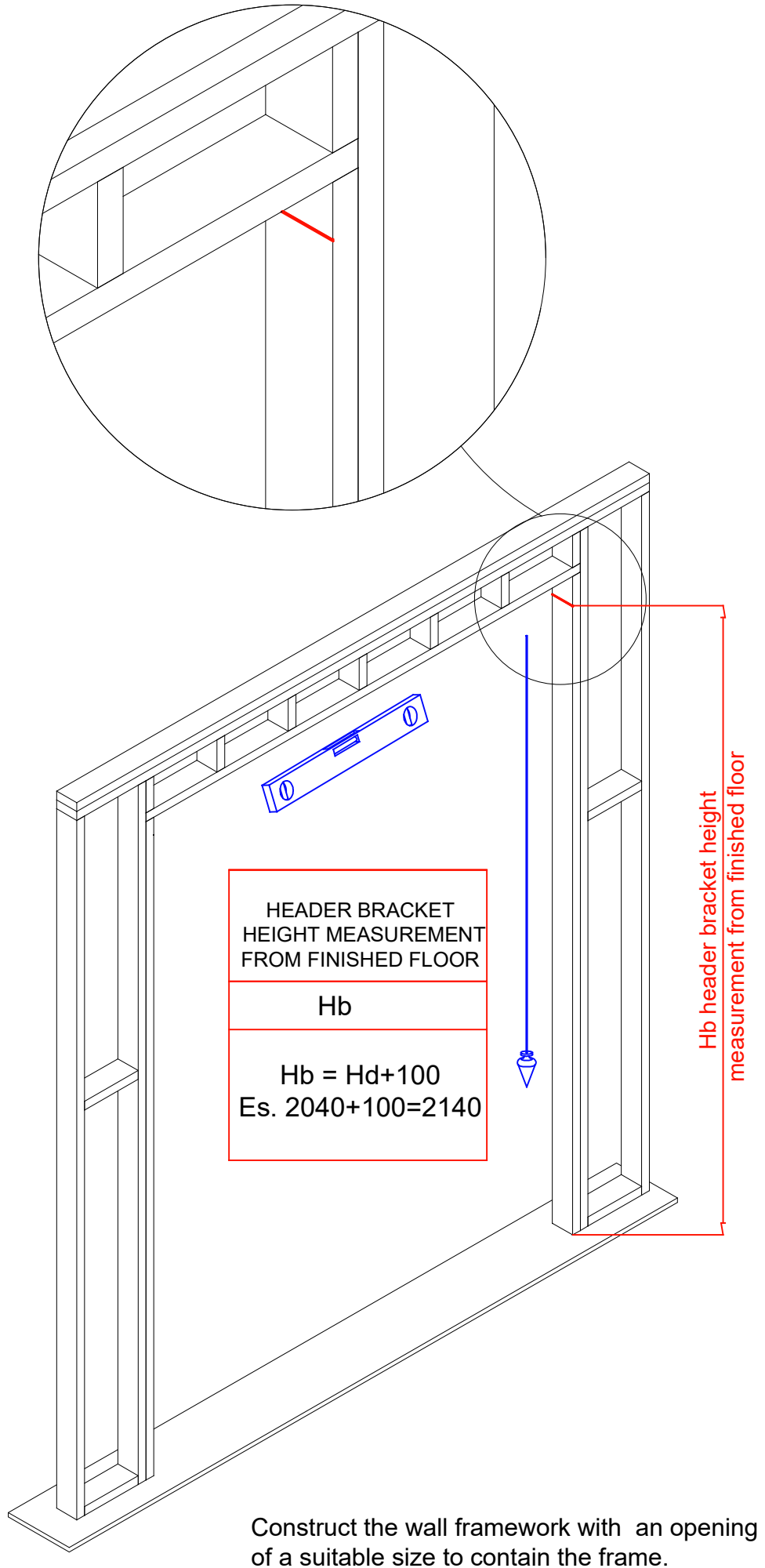

STEP 2:

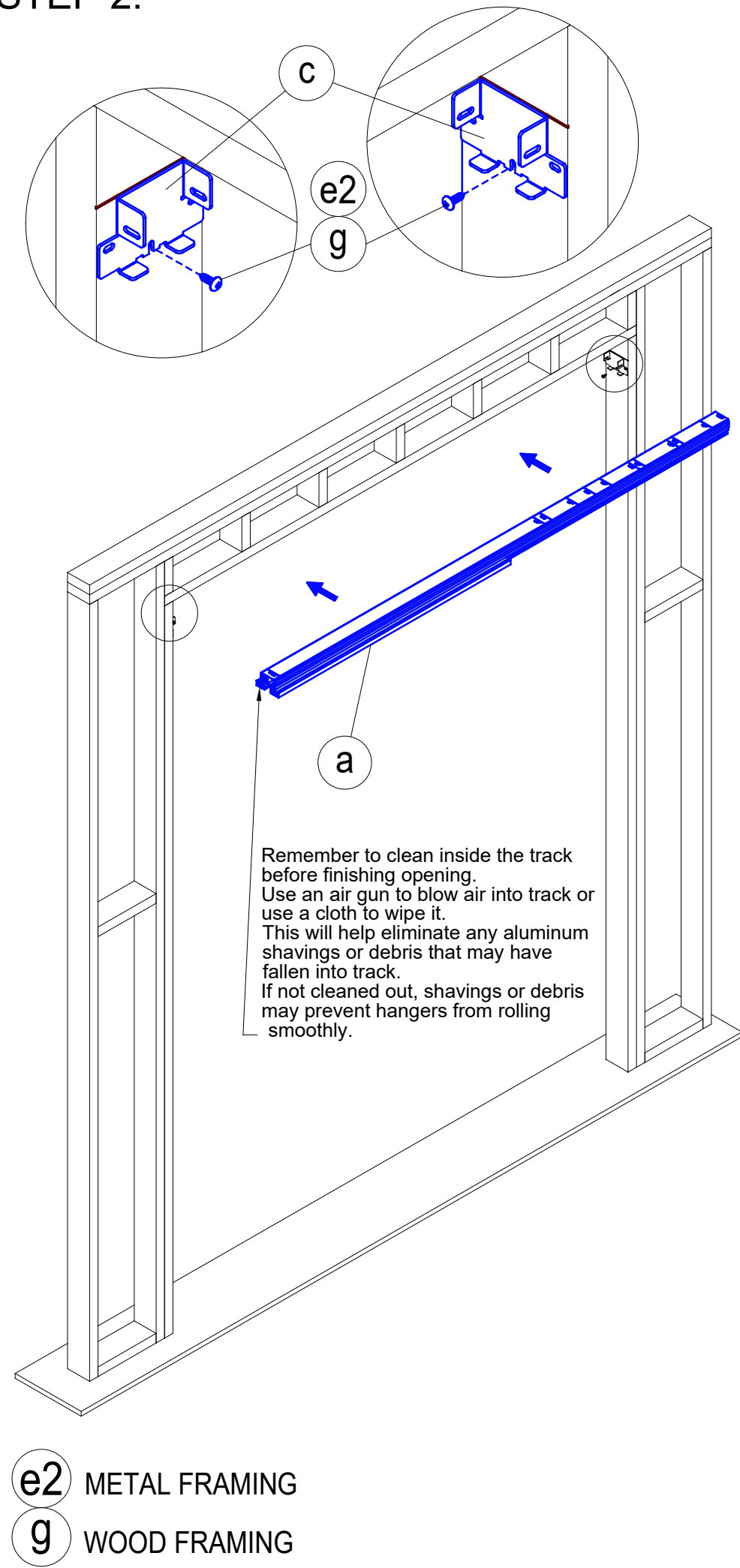

STEP 3:

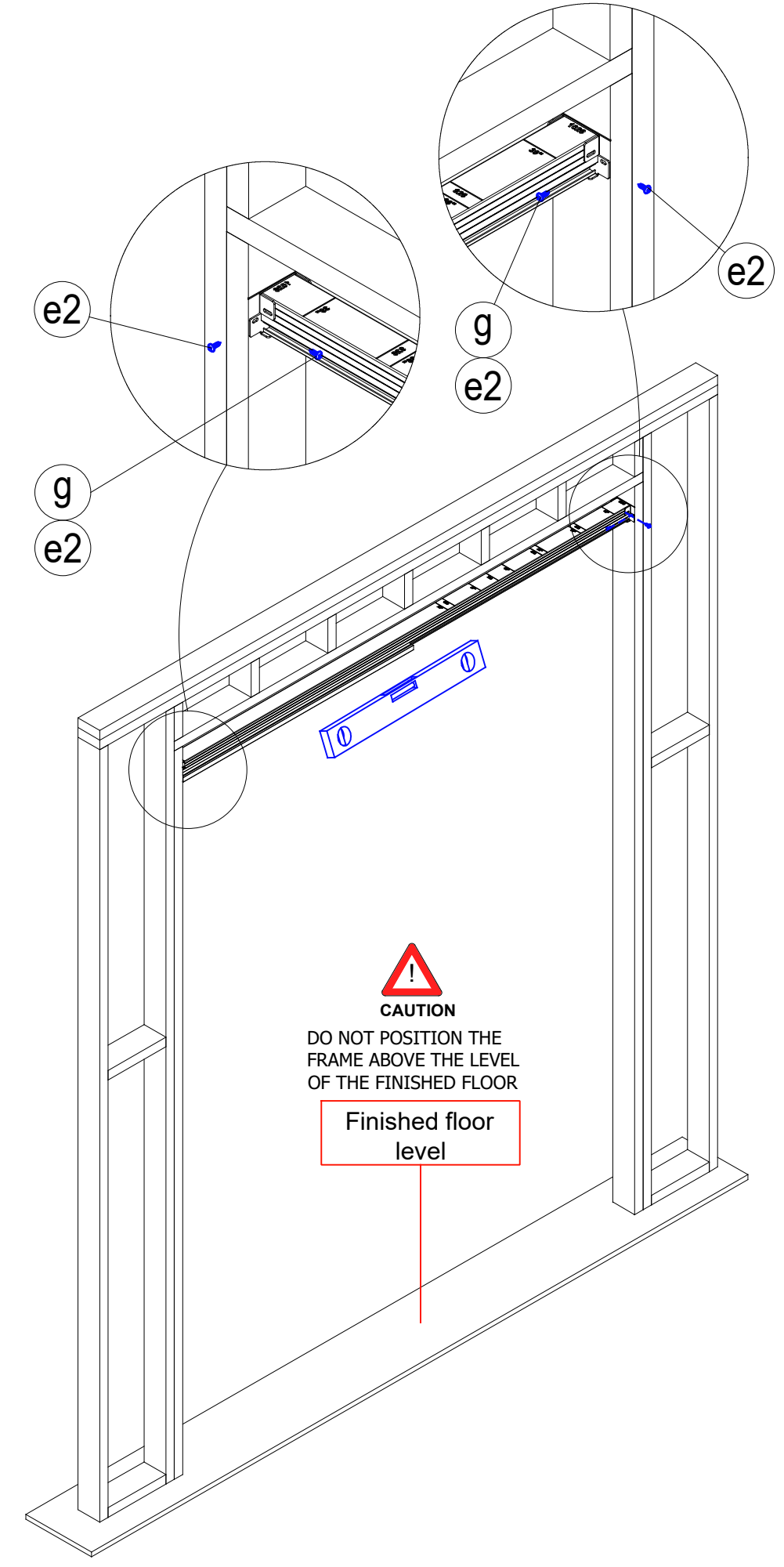

STEP 4:

FOOT BRACKET LOCATION DIMENSIONS A, B (METRIC)		
DOOR WIDTH	DIMENSION "A"	DIMENSION "B"
Ld	A	B
626	620	320
726	720	370
826	820	420
926	920	520
1026	1020	620

FOOT BRACKET LOCATION DIMENSIONS A, B (IMPERIAL)		
DOOR WIDTH	DIMENSION "A"	DIMENSION "B"
Ld	A	B
24"(610)	604	316
27"(686)	680	356
30"(762)	756	396
33"(838)	832	432
36"(914)	908	508
39"(990)	984	584

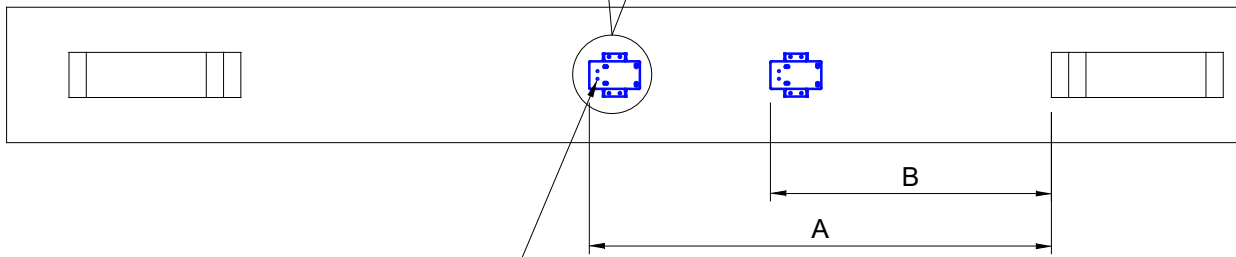
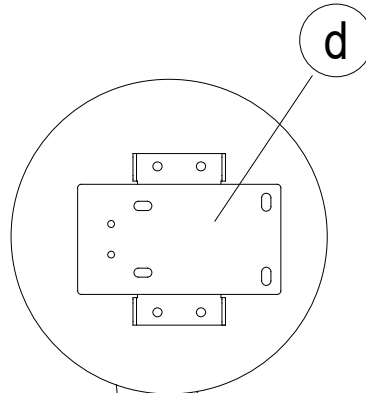

FRONT END OF FOOT BRACKET IS IDENTIFIED WITH 2 HOLES

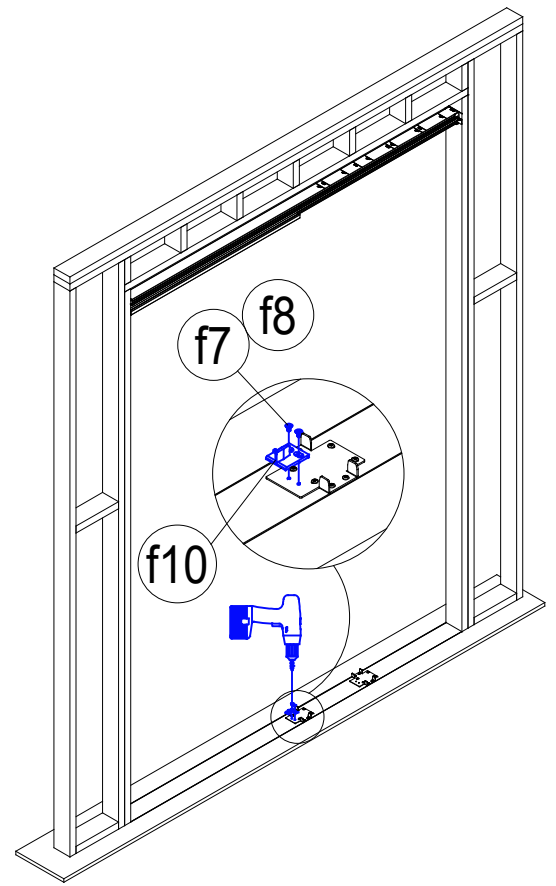
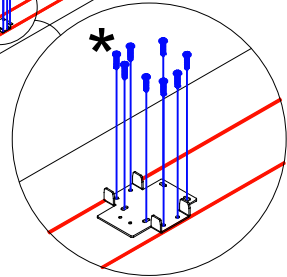
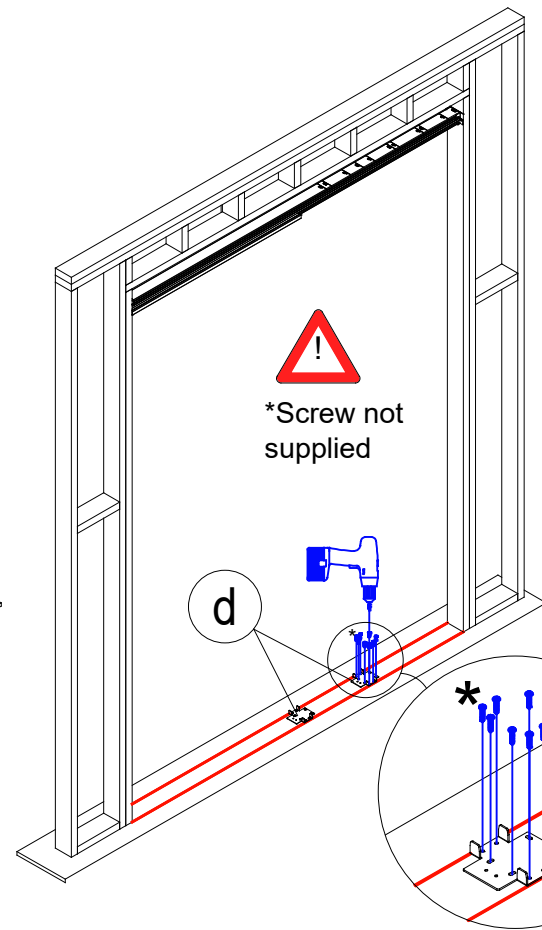
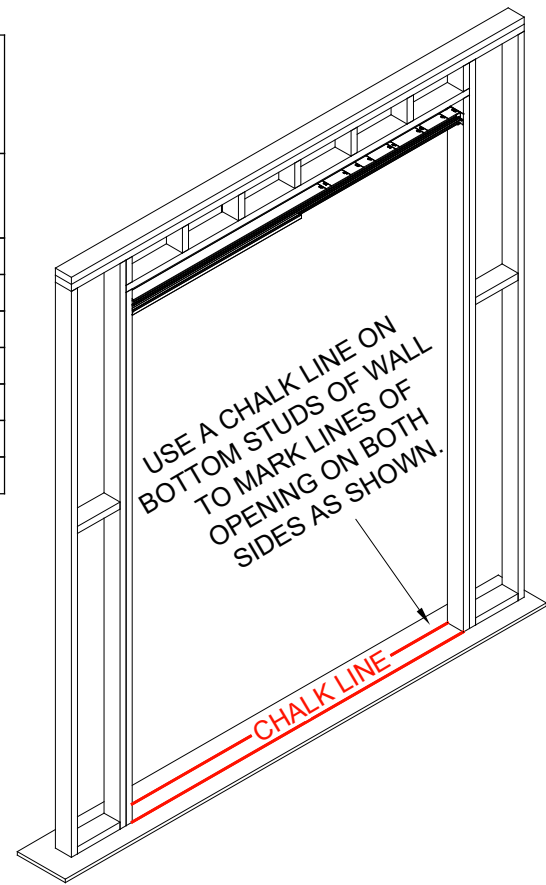

STEP 5:

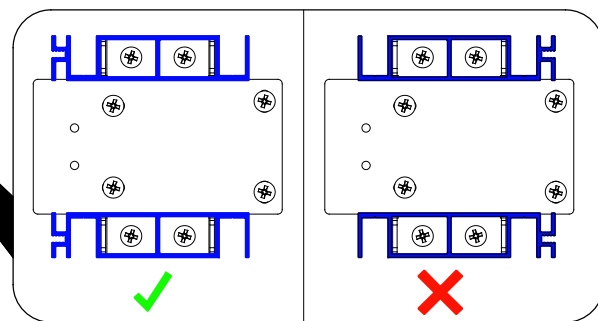
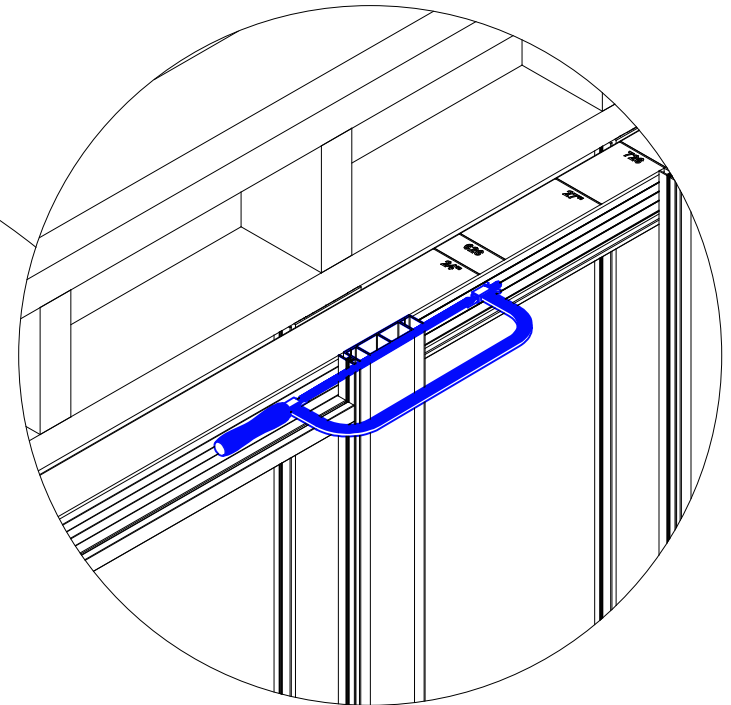
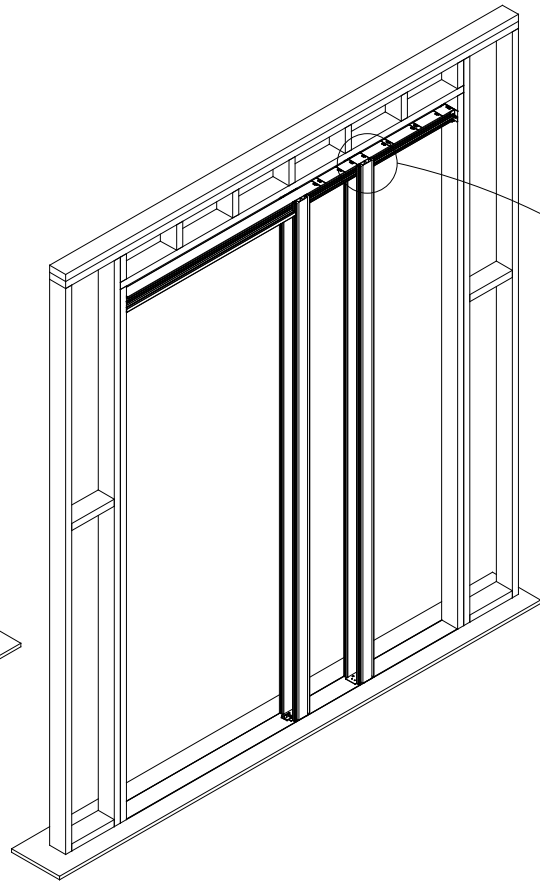
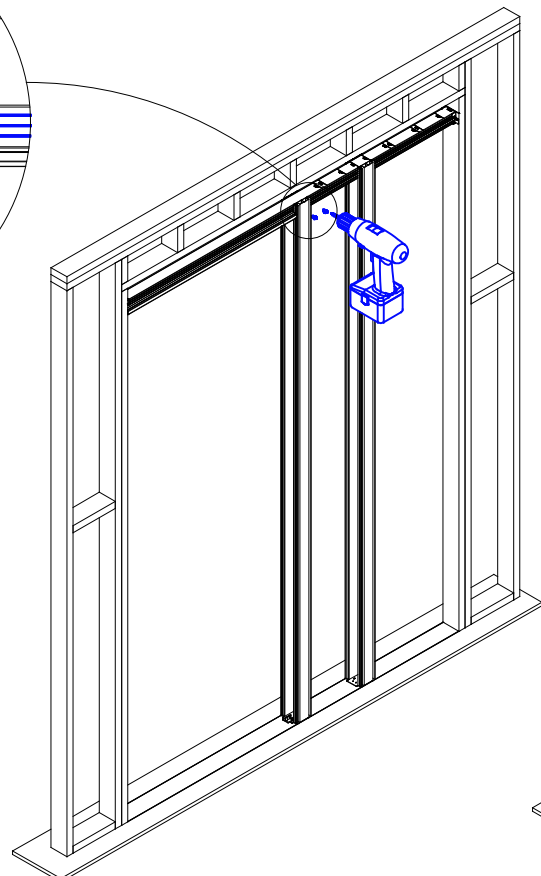
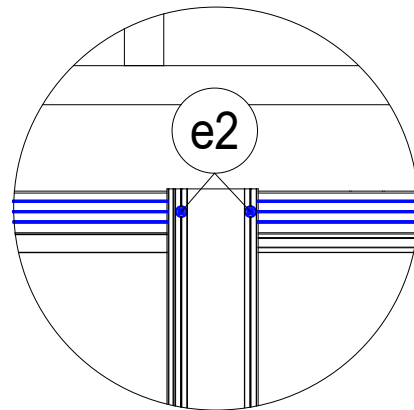
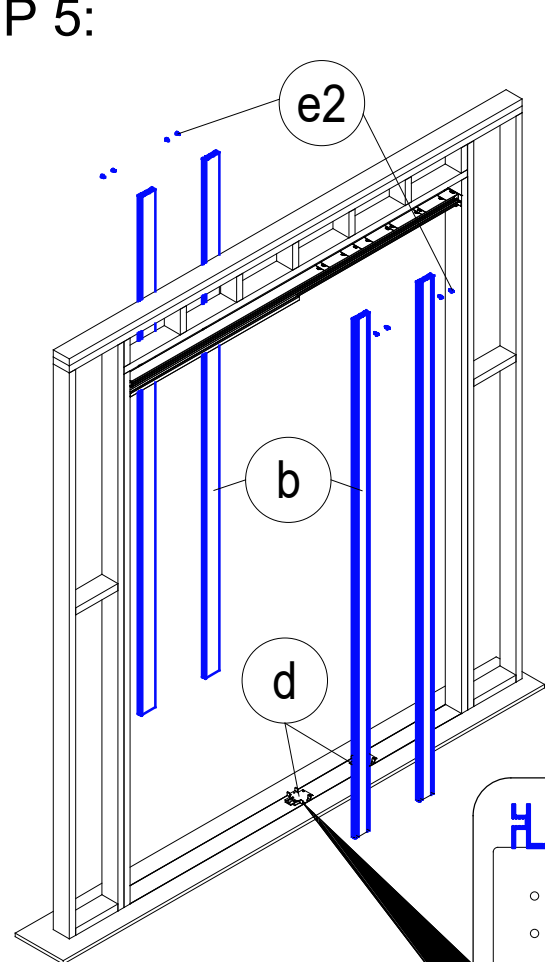

STEP 6:

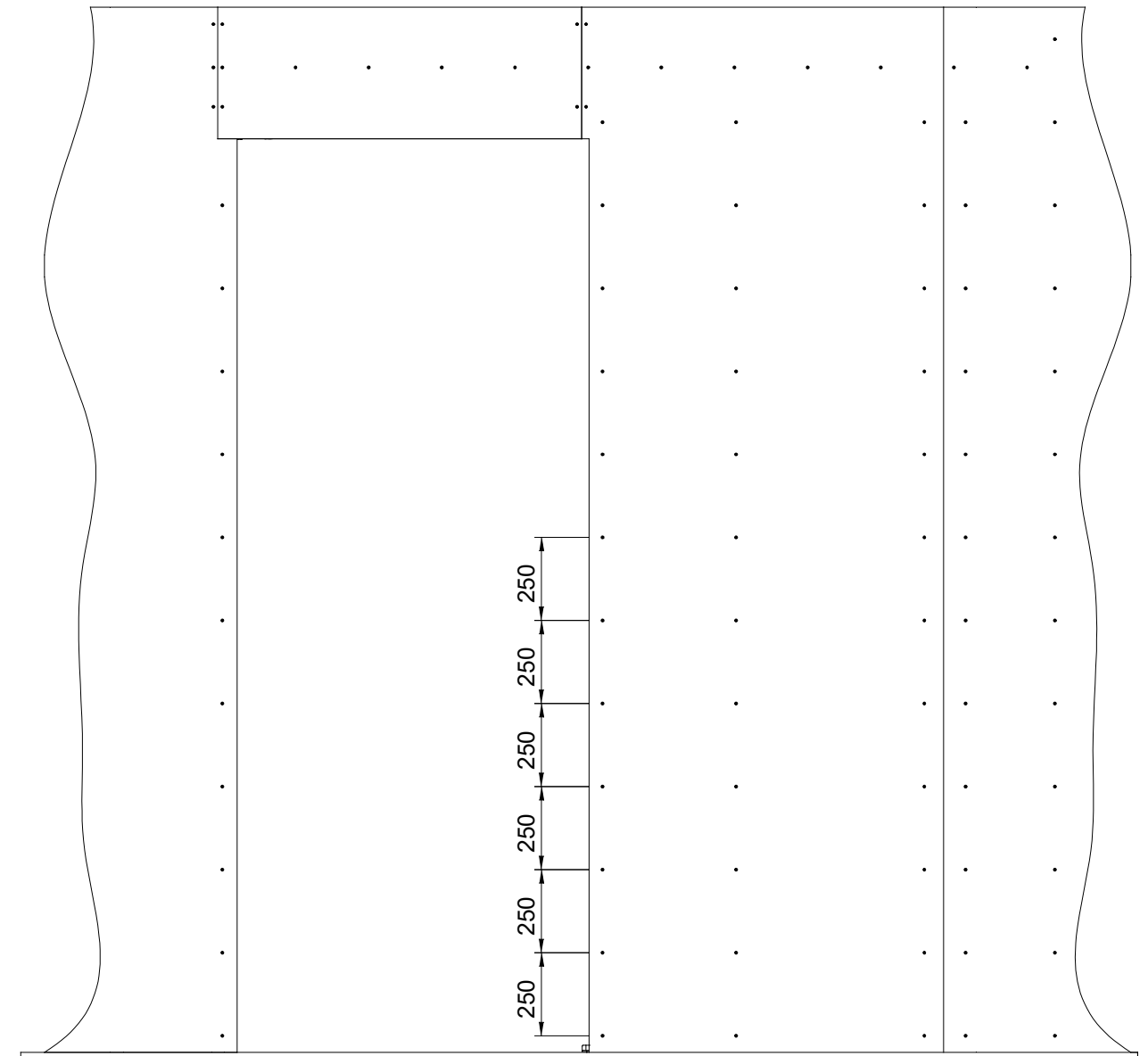
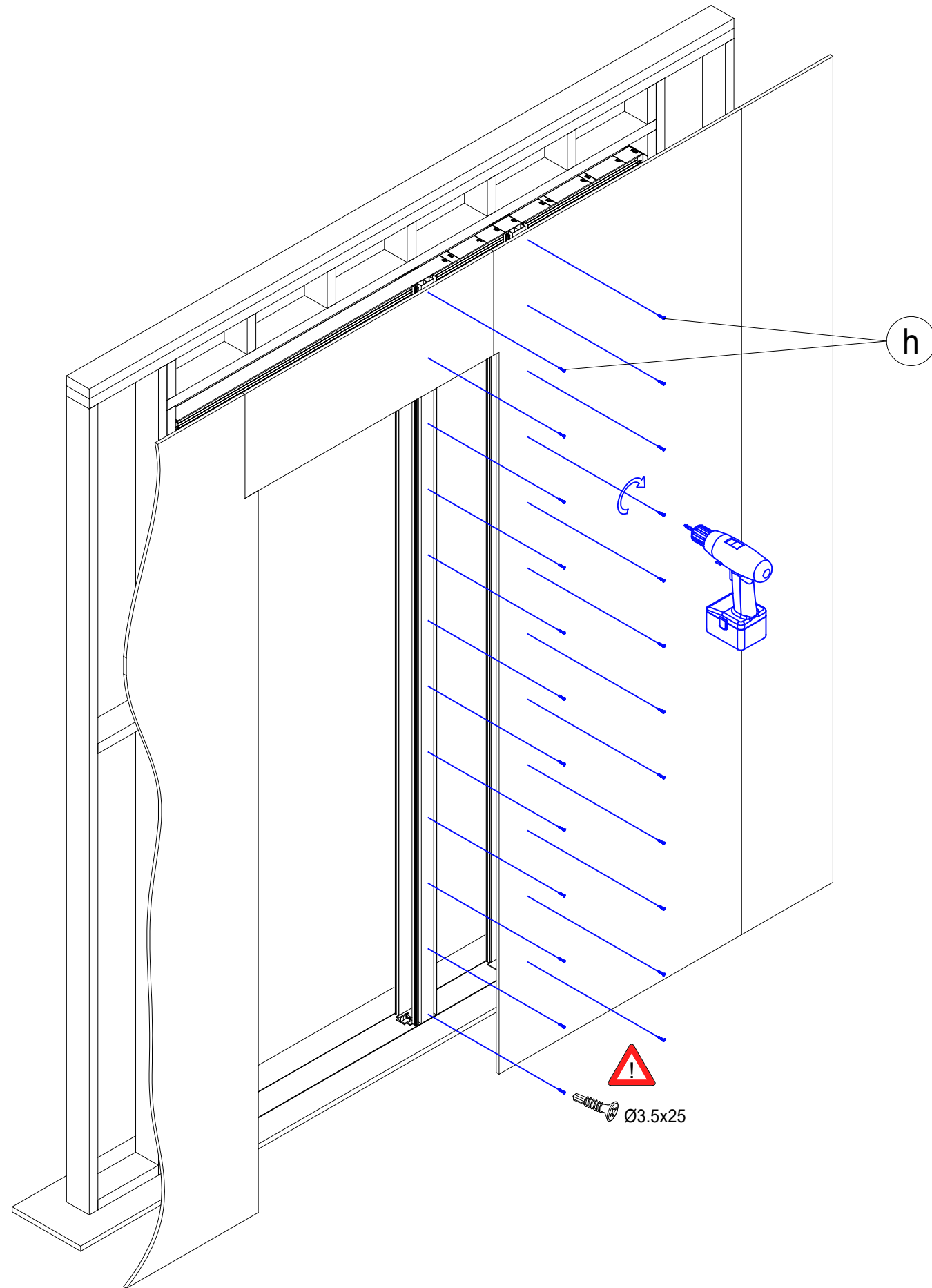

Apply an entire plasterboard sheet on the side of the metal box. Use one or two reinforced plasterboard sheets to give the metal box greater rigidity and increase its adherence.

SIZE DOUBLE

REQUIRED PRE-INSTALLATION INSTRUCTIONS

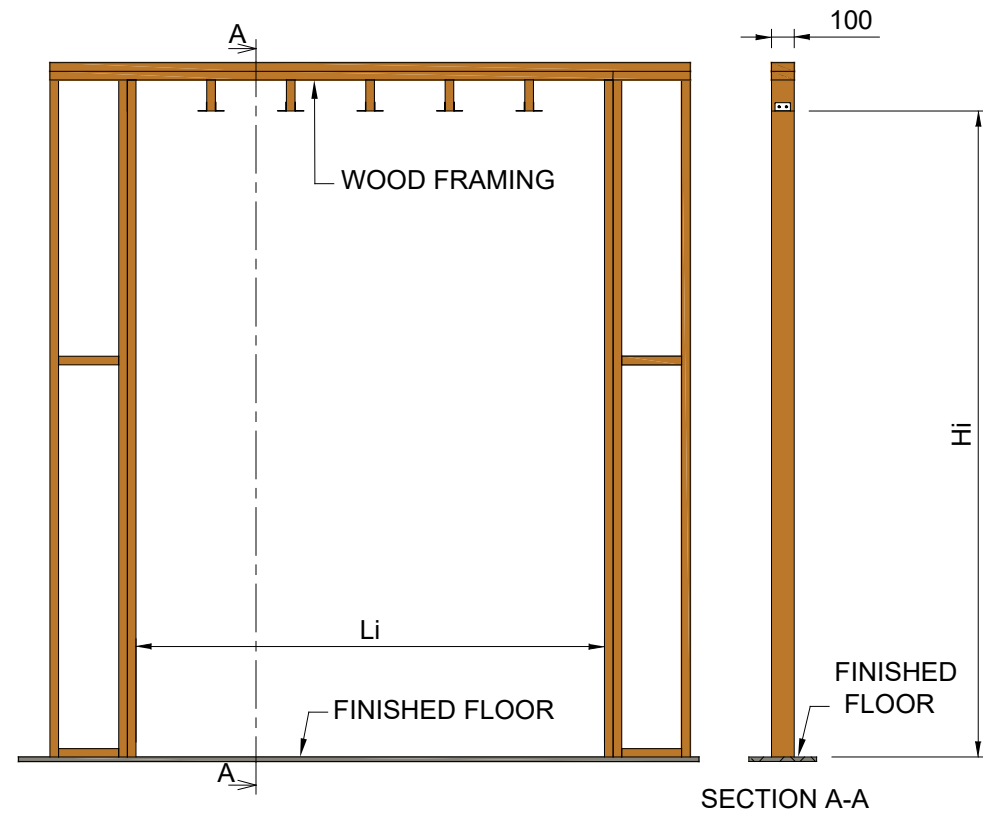

SECTION A-A

METRIC	DOOR WIDTH	STRUCTURAL OPENING WIDTH (Li)	IMPERIAL	DOOR WIDTH	STRUCTURAL OPENING WIDTH (Li)	HIGHT DOORS (Hd)	STRUCTURAL OPENING HEIGHT (Hi) FROM FINISHED FLOOR:
	2 x 626	2472		2 x 610 (24")	2408	MIN 1981 MAX 2710	Hd + 100 mm
	2 x 726	2872		2 x 686 (27")	2712		
	2 x 826	3672		2 x 762 (30")	3016		
	2 x 926	3872		2 x 838 (33")	3320		
	2 x 1026	4072		2 x 914 (36")	3624		
				2 x 990 (39")	3928		

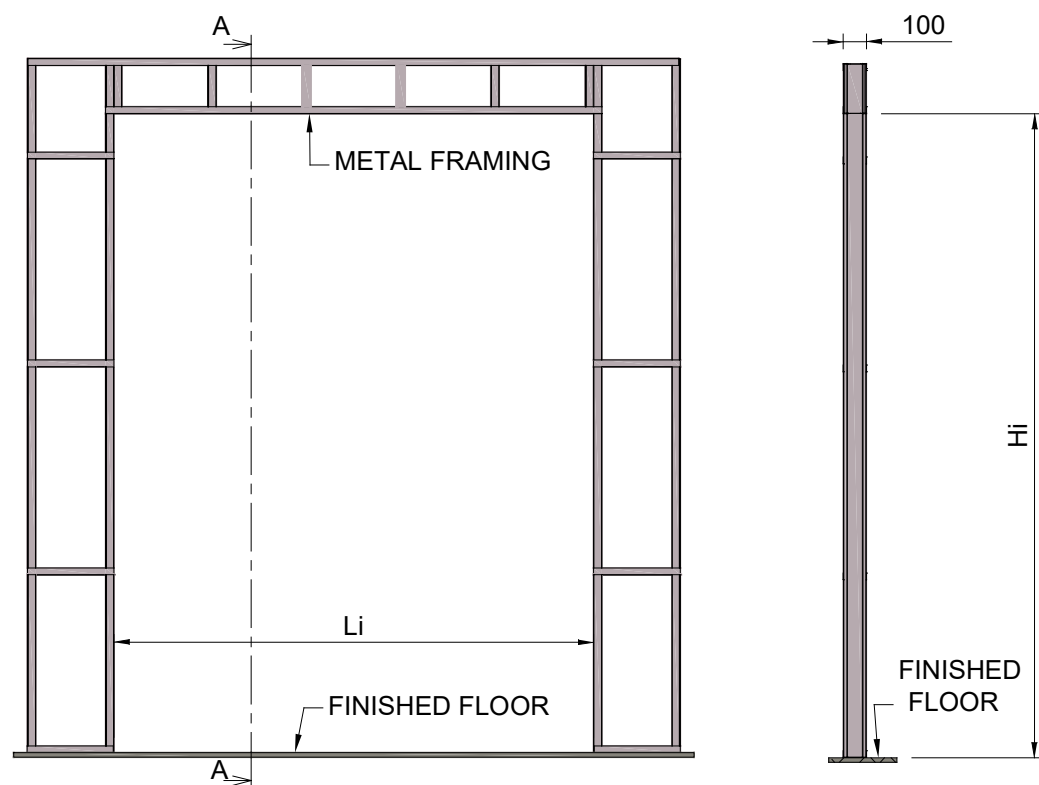

FRAMING DETAILS MAY DIFFER BASED ON REGION. REFER TO YOUR REGION'S BUILDING CODES FOR FRAMING DETAILS.

SIZE CHANGES

Cut track "1" to the desired size on the rear side.
Cut PVC profile bars "2" on the front side.

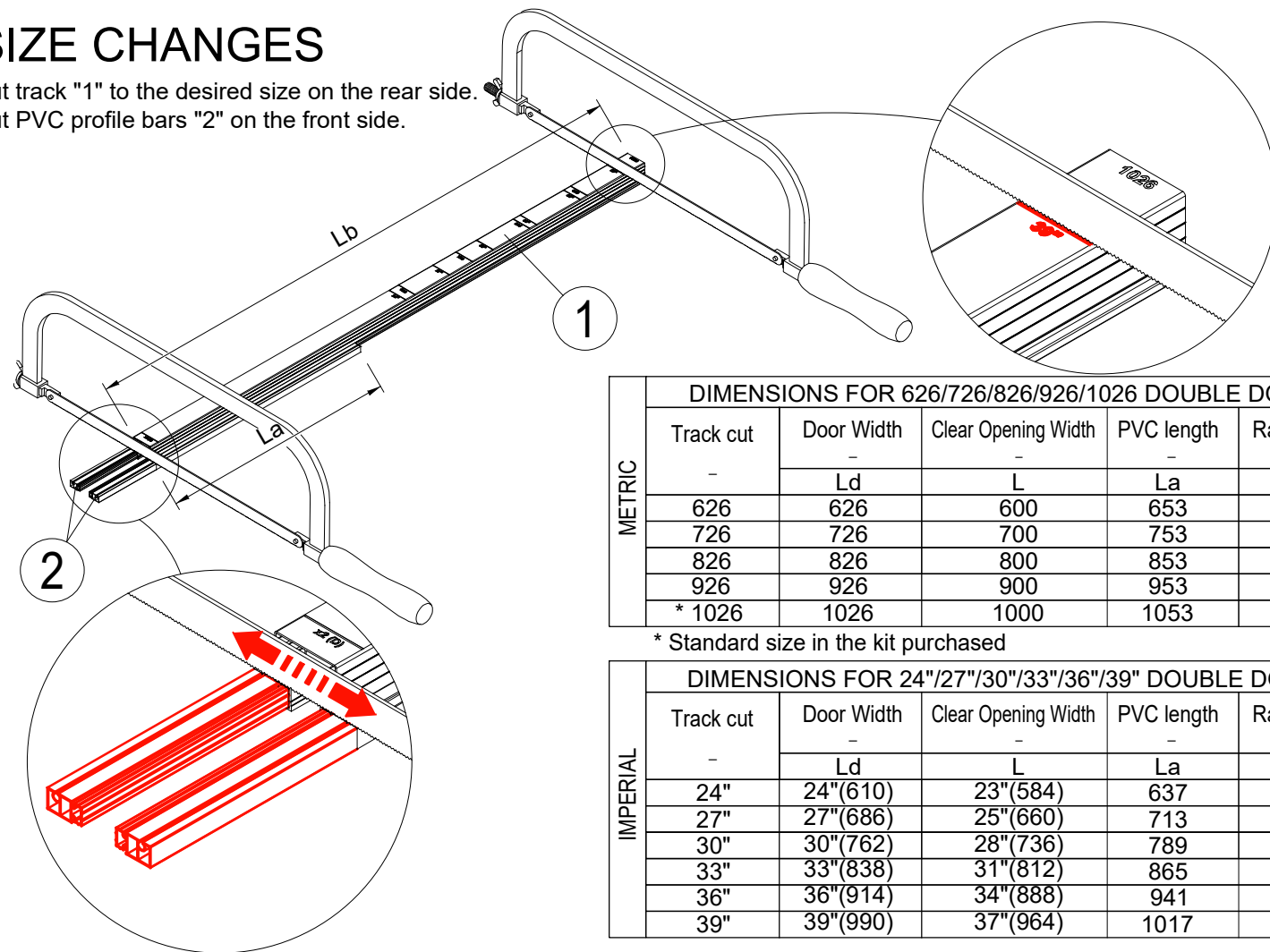

DIMENSIONS FOR 626/726/826/926/1026 DOUBLE DOOR					
METRIC	Track cut	Door Width	Clear Opening Width	PVC length	Rail length
	-	Ld	L	La	Lb
	626	626	600	653	1262
	726	726	700	753	1462
	826	826	800	853	1662
	926	926	900	953	1862
	* 1026	1026	1000	1053	2062

* Standard size in the kit purchased

DIMENSIONS FOR 24"/27"/30"/33"/36"/39" DOUBLE DOOR					
IMPERIAL	Track cut	Door Width	Clear Opening Width	PVC length	Rail length
	-	Ld	L	La	Lb
	24"	24"(610)	23"(584)	637	1230
	27"	27"(686)	25"(660)	713	1382
	30"	30"(762)	28"(736)	789	1534
	33"	33"(838)	31"(812)	865	1686
	36"	36"(914)	34"(888)	941	1838
	39"	39"(990)	37"(964)	1017	1990

SIZE DOUBLE

Cut track on the front side "X2 (D)"

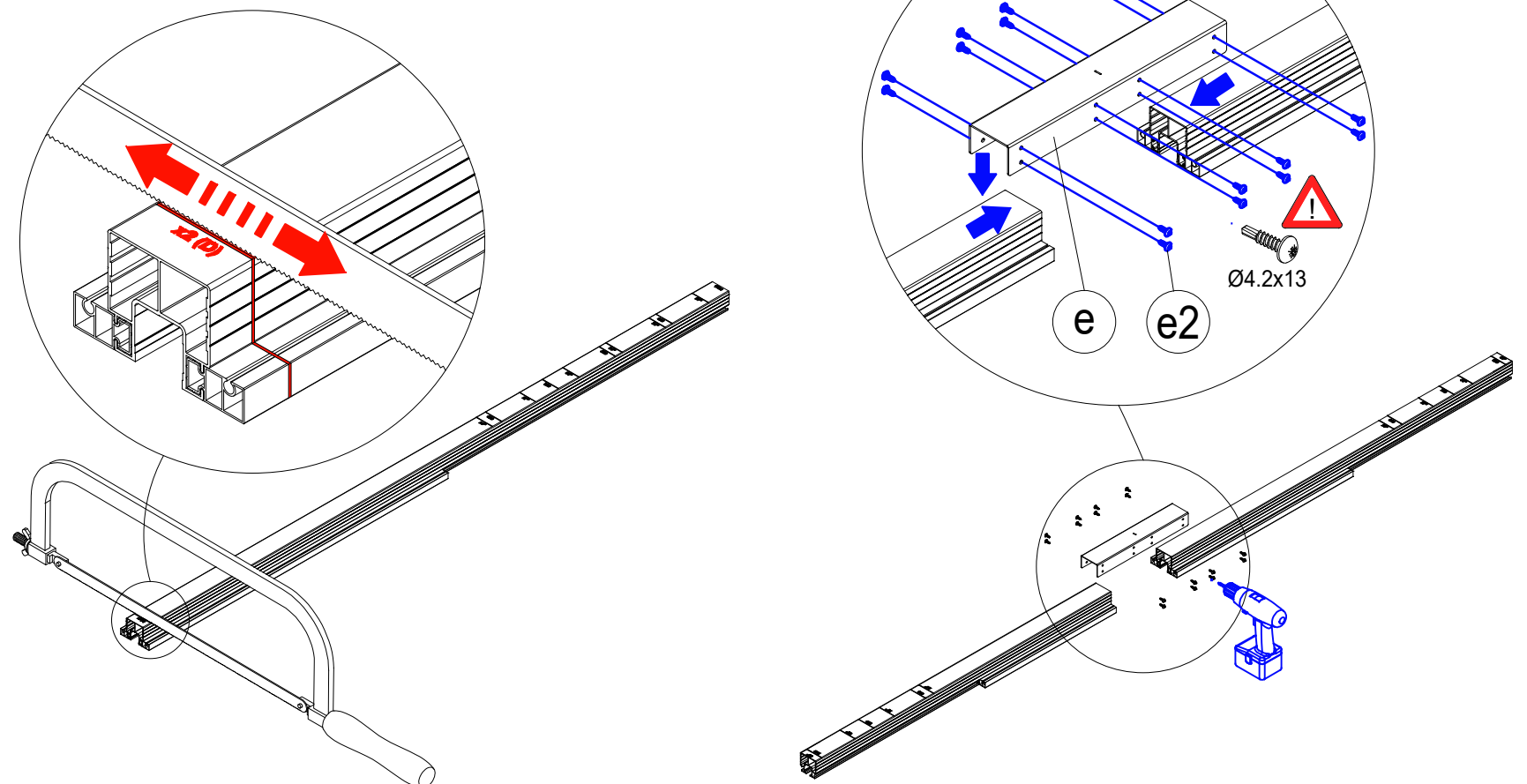

PLAN VIEW INSTRUCTIONS DOUBLE DOOR

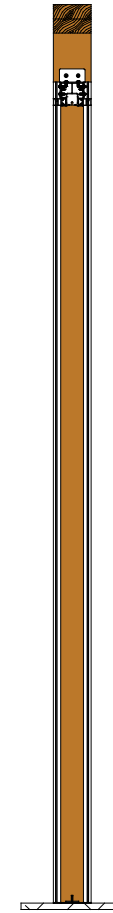
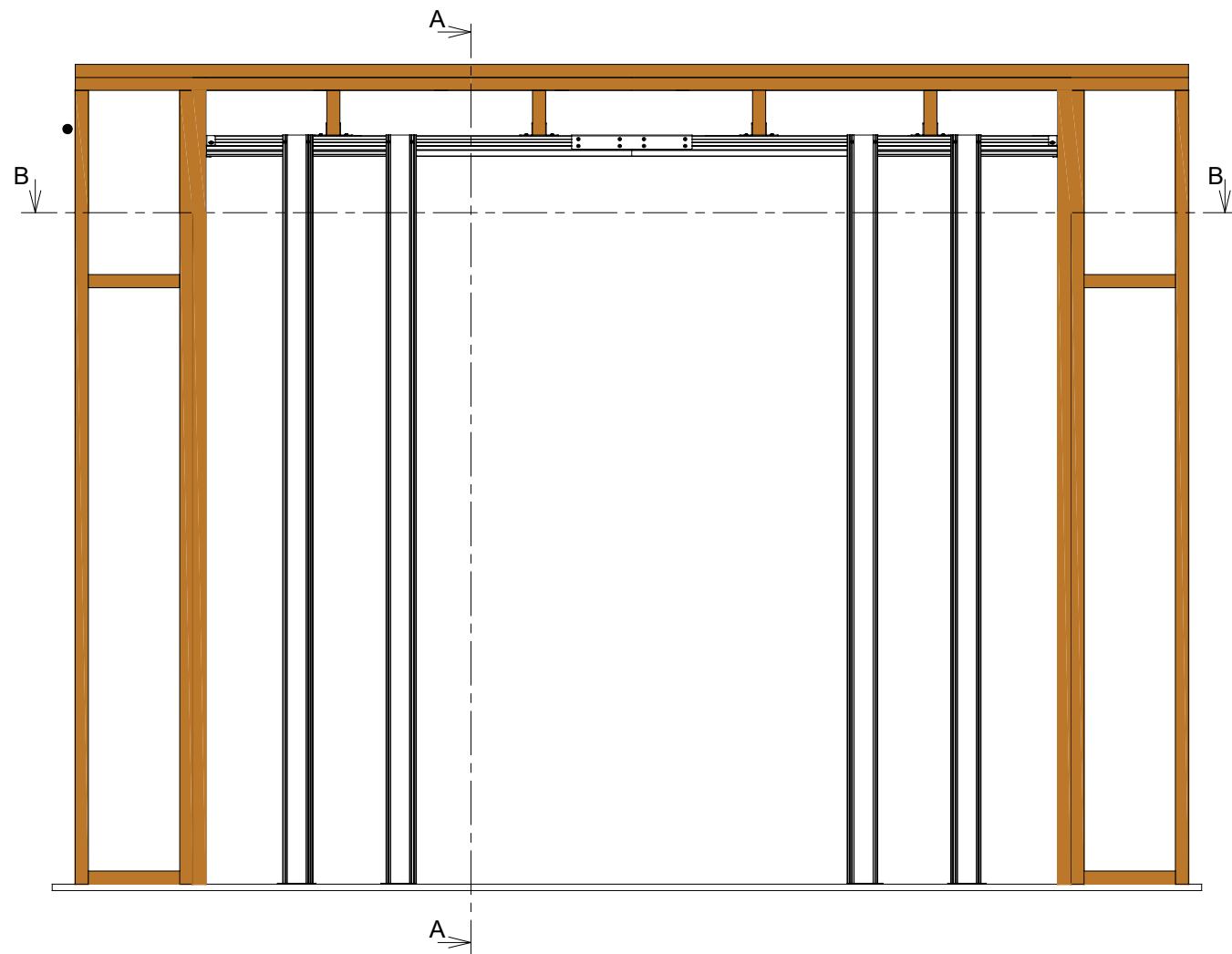

DIMENSIONS FOR 2x 626/726/826/926/1026 DOUBLE DOOR							
METRIC	Door Width	Dimension "A"	Dimension "B"	Opening Width without jamb	Cassette dimension	Structural opening width	Structural opening height
	Ld	A	B	Lg	Lc	Li	Hi
	2 x 626	620	320	1250	611	2472	Hd+100mm
	2 x 726	720	370	1450	711	2872	
	2 x 826	820	420	1650	811	3272	
	2 x 926	920	520	1950	911	3672	
	2 x 1026	1020	620	2050	1011	4072	

DIMENSIONS FOR 2x 24"/27"/30"/33"/36"/39" DOUBLE DOOR							
IMPERIAL	Door Width	Dimension "A"	Dimension "B"	Opening Width without jamb	Cassette dimension	Structural opening width	Structural opening height
	Ld	A	B	Lg	Lc	Li	Hi
	2 x 24"	604	316	1218	595	2408	Hd+100mm
	2 x 27"	680	356	1370	671	2712	
	2 x 30"	756	396	1522	747	3016	
	2 x 33"	832	432	1674	823	3320	
	2 x 36"	908	508	1826	899	3624	
	2 x 39"	984	584	1978	975	3928	

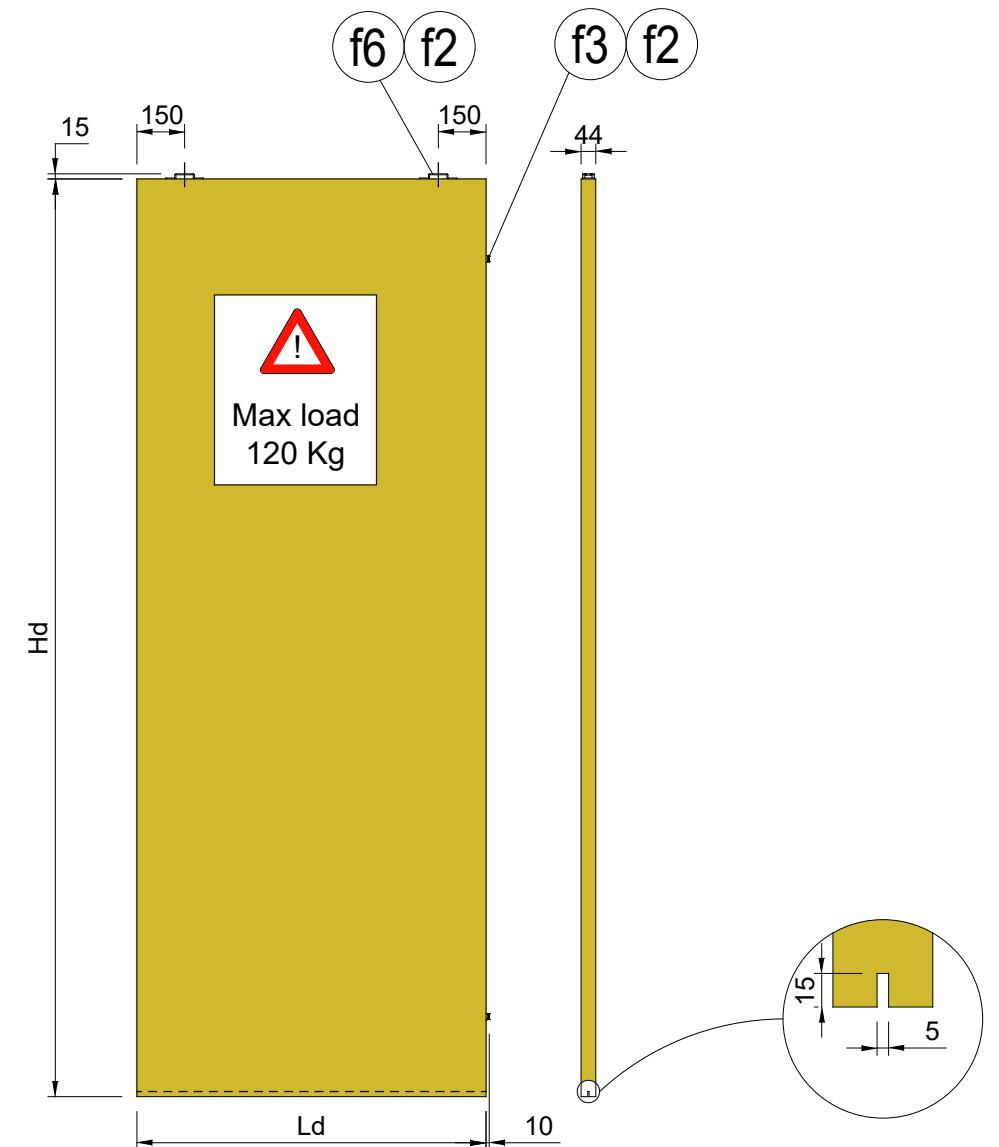
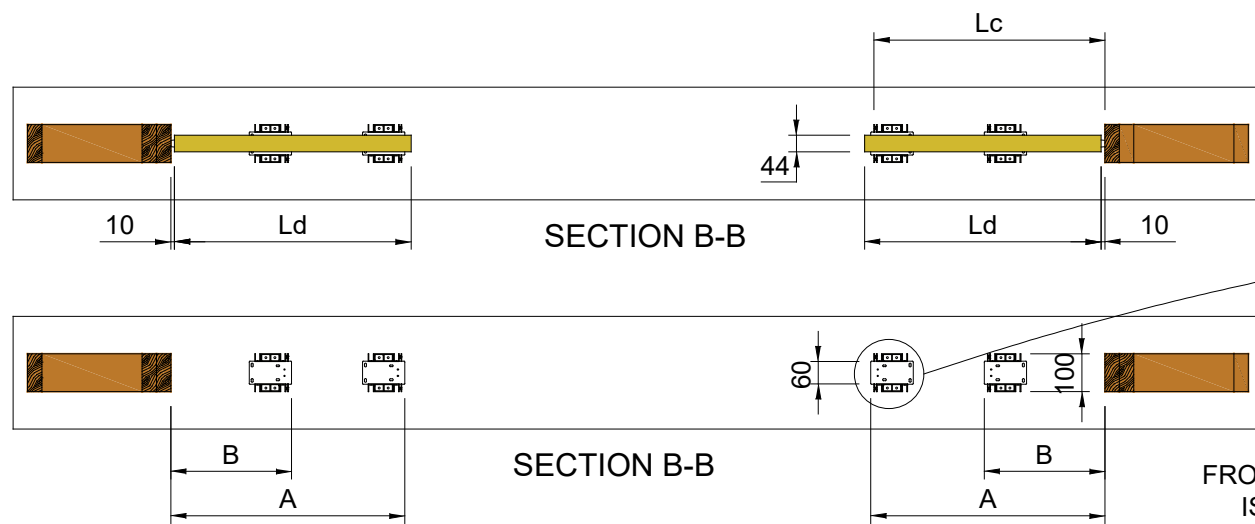

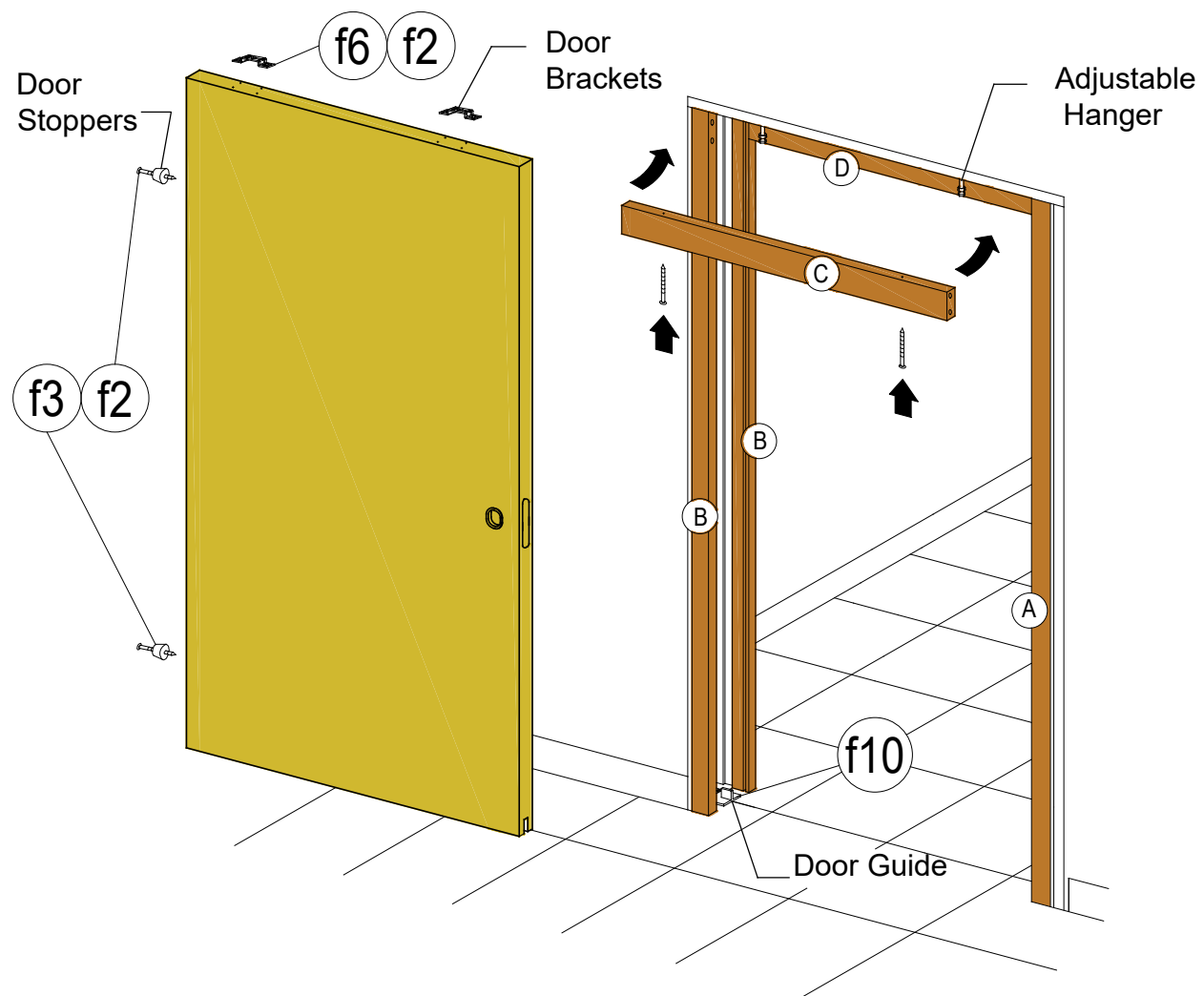

PREPARING THE JAMBS & END POSTS

SINGLE DOOR		END POSTS		
OPENING SIZE	DOOR	A	B	C / D
L x H mm	Ld x Hd mm	mm	mm	mm
600 x 2030	626 x 2040			600
700 x 2030	726 x 2040			700
800 x 2030	826 x 2040	2080	2080	800
900 x 2030	926 x 2040			900
1000 x 2030	1026 x 2040			1000
584 x 1971	610 x 1981			584
660 x 1971	686 x 1981			660
736 x 1971	762 x 1981	2021	2021	736
812 x 1971	838 x 1981			812
888 x 1971	914 x 1981			888
964 x 1971	990 x 1981			964

Consult the table below to cut the cassette edge covers, end post and crosspieces to size, and insert the seals. (brush seals in B and rubber seals in A)

DOUBLE DOOR		END POSTS		
OPENING SIZE	DOOR	B	C / D	
L x H mm	Ld x Hd mm	mm	mm	mm
1200 x 2030	626 x 2040			1200
1400 x 2030	726 x 2040			1400
1600 x 2030	826 x 2040	2080		1600
1800 x 2030	926 x 2040			1800
2000 x 2030	1026 x 2040			2000
1168 x 1971	610 x 1981			1168
1320 x 1971	686 x 1981			1320
1472 x 1971	762 x 1981	2021		1472
1624 x 1971	838 x 1981			1624
1776 x 1971	914 x 1981			1776
1624 x 1971	838 x 1981			1624

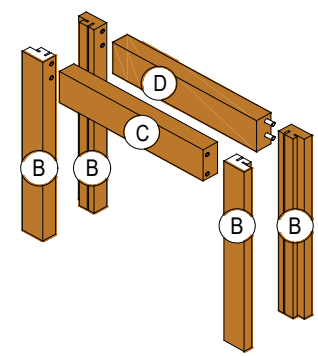
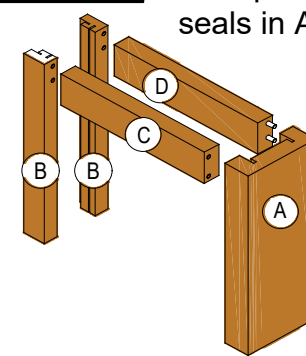

FITTING THE JAMBS & DOOR

3 Fit the cassette edge cover 'B' onto the cassette edge as shown. This is usually fitted on the corridor side or the more visible side.

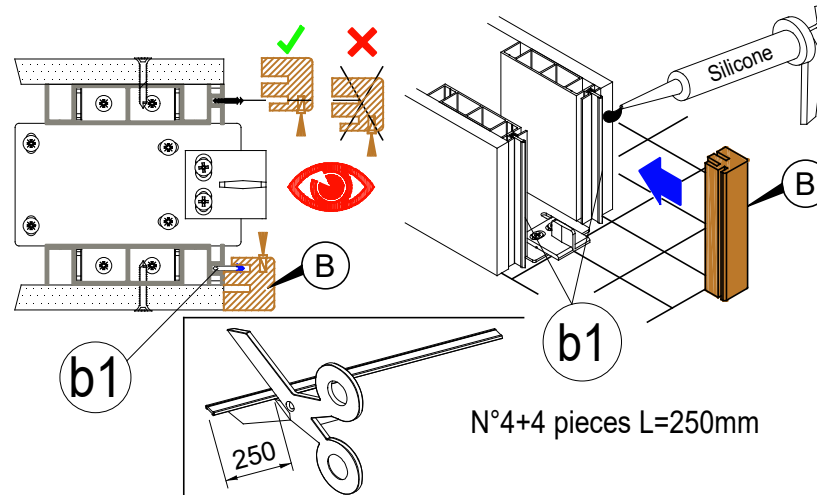

6 Slide crosspiece 'D' into the jamb end post 'A' with the dowells provided. Check A's vertical position and fasten to wooden jamb 'E'. Then secure the free end of crosspiece 'D' to the plastic section of the track with a vertical screw from the top

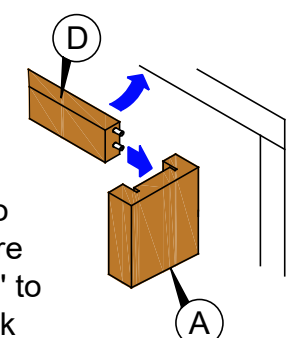

7 Fit the remaining cassette edge cover 'B' onto the cassette edge. Ensure the positioning is correct (Fig 3). It is helpful to pre-drill holes

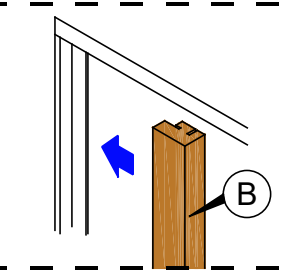

8 Secure crosspiece 'C' with vertical screws at each end. This is essential to allow for adjustment and routine maintenance.

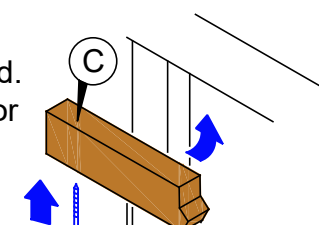

*For double doors crosspiece C/D will travel from cassette edge cover 'B' to the opposite edge cover 'B'

DOOR PREPARATION

1 The door will need to have a 5mm router cut in the centre of the door edge bottom to accommodate the floor guide. Some door suppliers may do this before shipping however extra care needs to be made during this process. The cut will need to run the entire width of the door and be 15mm in depth.

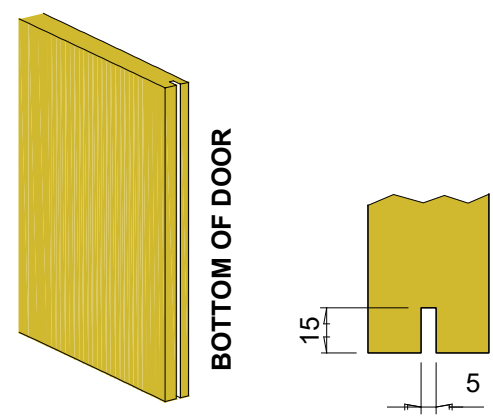

2 Fit the rubber directly to the rear edge of the panel for a total disappear of the door. if you wish door to project slightly, fix between the rubber and the edge of the door a timber spacer, as illustrated.

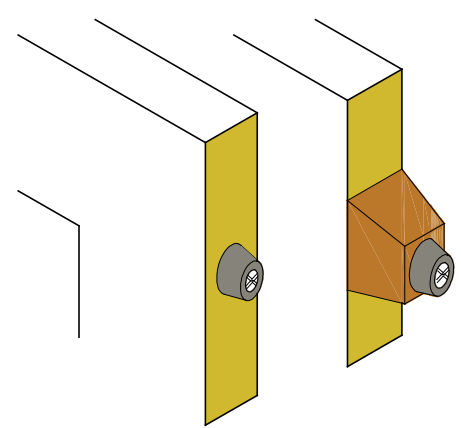

4 Fix the two door hanging brackets to the top of the door 150mm away from the door edge (as shown) with the 4.5x25 screws supplied.

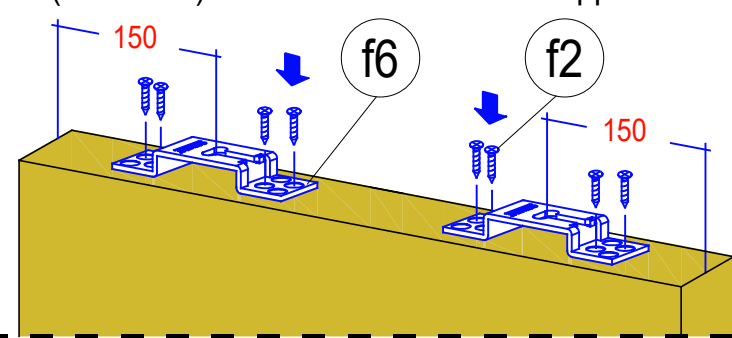

5 Fit the adjustable hangers and the retaining hook into the track. Hook on the door and adjust the hangers and retaining hook accordingly

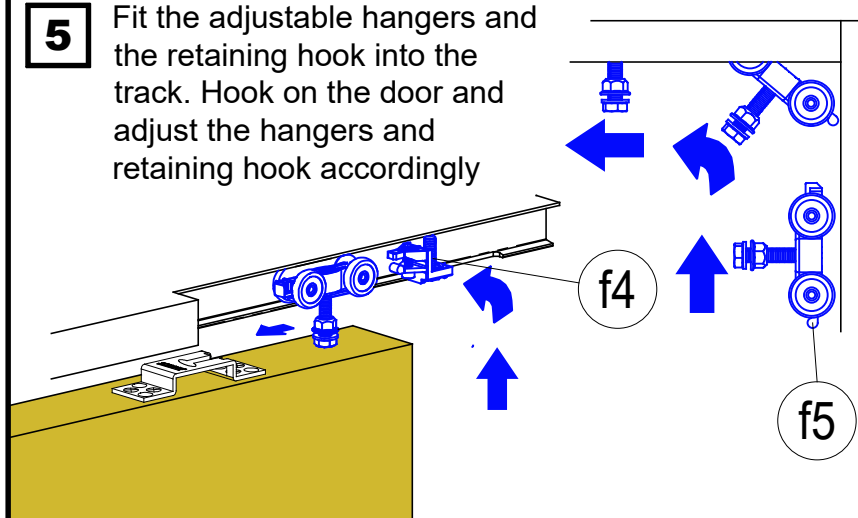

INSTALLATION OVERVIEW

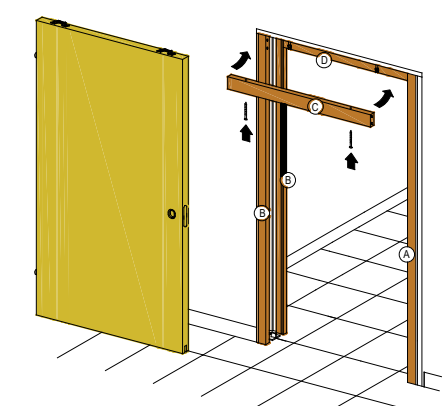

The standard installation is now complete. Once adjustments have been made for fine tuning, optional accessories should be fitted. It is preferable to fit these upon initial installation, otherwise architrave and crosspiece 'C' would need to be removed.

PLAN VIEW INSTRUCTIONS

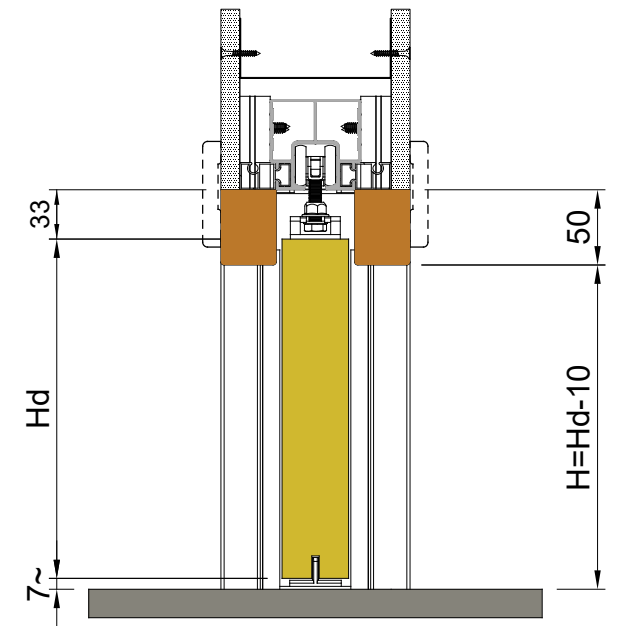
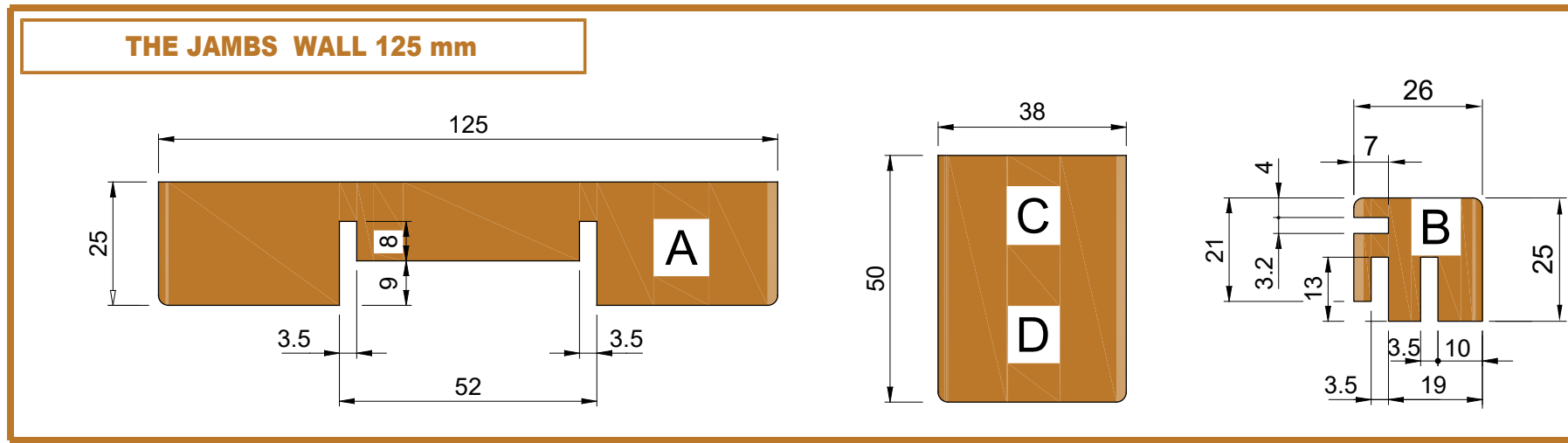

(DOOR IN OPEN POSITION)

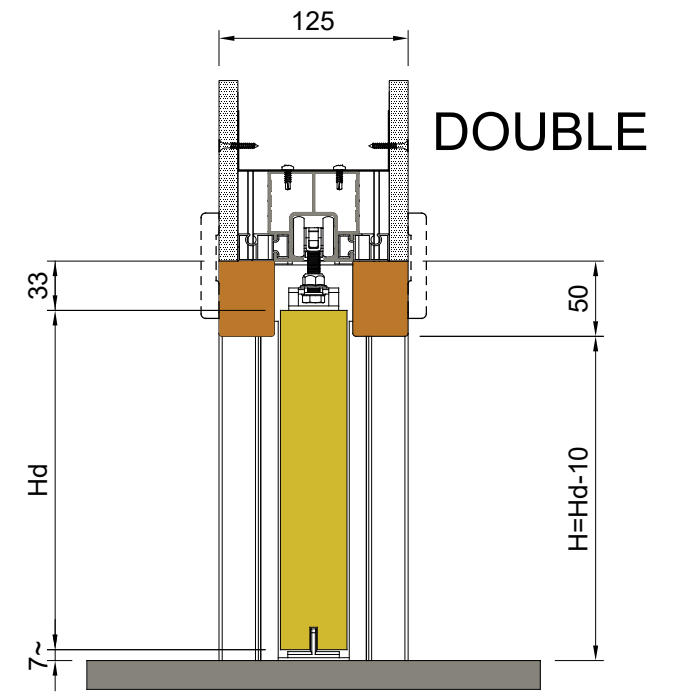
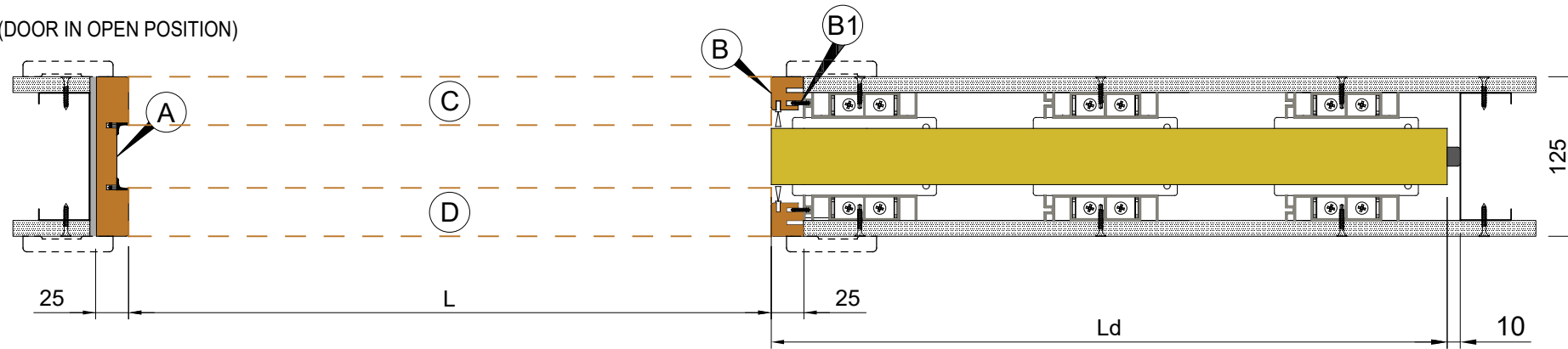

(DOOR IN CLOSED POSITION)

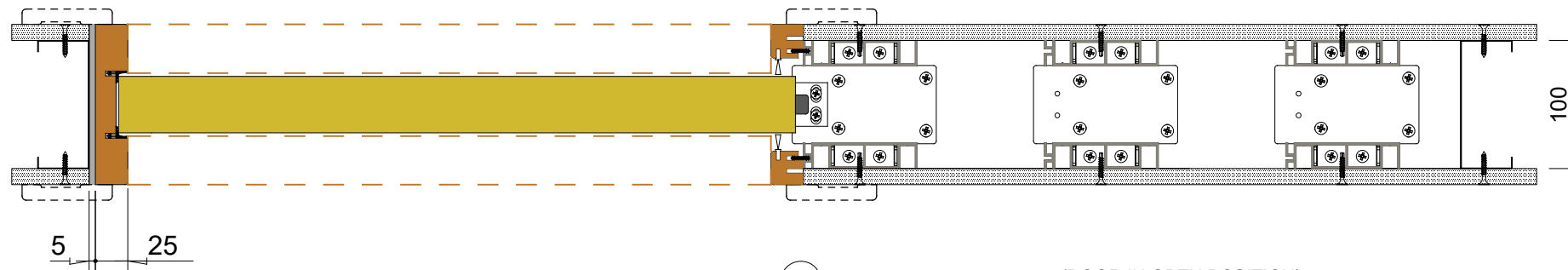

(DOOR IN OPEN POSITION)

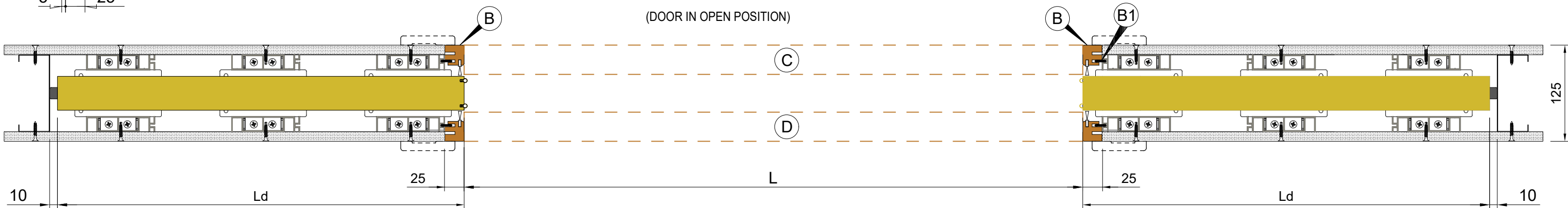

(DOOR IN CLOSED POSITION)

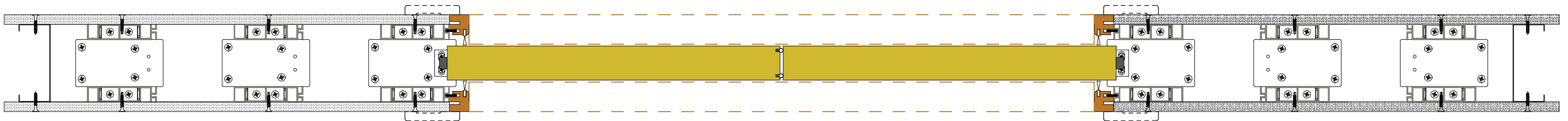



The information given in this document is for descriptive purposes only. SCRIGNO S.p.A. will not be held responsible for any inaccuracies caused by printing errors,transcription errors or for any other reason,and reserves the right to make modifications, without giving prior notice,for the improvement of its products.
The reproduction,including the partial reproduction,of this document is severely prohibited within the terms of the Law.

Scigno S.p.A. Unipersonale
Via Casale, 975 - 47822 - Sant'Ermite di Santarcangelo (RN)
- Italy
Tel.+39 0541 757711 - Fax +39 0541 757780
www.scigno.net e-mail: scigno@scigno.it